

**SUBJECT:** AN ORDINANCE OF THE MATANUSKA-SUSITNA BOROUGH ASSEMBLY AMENDING MSB 17.73 MULTIFAMILY DEVELOPMENT DESIGN STANDARDS TO ALIGN PERMITTING AND DESIGN STANDARDS WITH THE SCALE AND COMPLEXITY OF DEVELOPMENT PROJECTS.

**AGENDA OF:** April 21, 2026

<b>ASSEMBLY ACTION:</b>
-------------------------

**AGENDA ACTION REQUESTED:** Refer to Planning Commission for 90 days.

Route To	Signatures
Originator	<div style="text-align: right;">4 / 1 0 / 2 0 2 6</div> <p>X      A l e x   S t r a w n</p> <hr/> <p><small>Signed by: Alex Strawn</small></p>
Department Director	<div style="text-align: right;">4 / 1 0 / 2 0 2 6</div> <p>X      A l e x   S t r a w n</p> <hr/> <p><small>Signed by: Alex Strawn</small></p>
Finance Director	<div style="text-align: right;">4 / 1 4 / 2 0 2 6</div> <p>X      C h e y e n n e   H e i n d e l</p> <hr/> <p><small>Signed by: Cheyenne Heindel</small></p>
Borough Attorney	<div style="text-align: right;">4 / 1 4 / 2 0 2 6</div> <p>X      S h a n n o n   B o d o l a y   f o r   N S</p> <hr/> <p><small>Signed by: Shannon Bodolay</small></p>
Borough Manager	<div style="text-align: right;">4 / 1 4 / 2 0 2 6</div> <p>X      M i c h a e l   B r o w n</p> <hr/> <p><small>Signed by: Mike Brown</small></p>
Borough Clerk	<div style="text-align: right;">4 / 2 1 / 2 0 2 6</div> <p>X      L o n n i e   M c K e e . . .</p> <hr/> <p><small>Signed by: Lonnie McKechnie</small></p>

**ATTACHMENT (S) :** Ordinance Serial No. 26-031 (10pp)  
 MSB 17.73 (15pp)  
 MSB 17.125 (17pp)  
 MSB 2022 Subdivision Construction Manual (54pp)  
 MSB Design Criteria Manual Chapter Two (25pp)  
 Planning Commission Resolution No. 26-\_\_\_ ( pp)

**SUMMARY STATEMENT:** This ordinance is at the request of Assemblymember Sumner.

The amendments to Title 17 address multiple aspects of multifamily development, with the purpose of clarifying permit requirements, improving safety and circulation standards, and providing exemptions for smaller-scale developments. These changes support the borough’s goals of promoting orderly growth while protecting

public health, safety, and welfare.

The ordinance also addresses definitions relevant to multifamily development. "Primary vehicle access" is modified to remove a development standard from within the definition itself. "Vehicular circulation" is defined to establish minimum design requirements for internal drive systems, promoting safe and efficient movement of vehicles on-site.

Applicability standards for multifamily regulations are clarified under section 17.73.030. Developments with two or fewer dwelling units per lot are now exempt from this chapter, ensuring that small scale residential projects are not subject to standards intended for larger-scale multifamily housing.

To improve fire access and traffic movement, the ordinance outlines vehicular circulation requirements based on project size. All bridges and water crossings leading to more than one dwelling unit must be designed and constructed in accordance with the Borough Design Criteria Manual.

The adoption of drainage requirements ensure developments are designed to handle stormwater appropriately. Drainage plans must be certified by an engineer and meet specific runoff and detention standards.

In summary, this ordinance is consistent with the MSB comprehensive plan by addressing safety, accessibility, and environmental stewardship while balancing the regulatory burden for small-scale developments.

#### Matanuska-Susitna Borough Comprehensive Plan

Goal E-3: Create an attractive environment for business investment.

Policy E3-2: Institute appropriate land use guidelines and regulations that reduce land use conflicts and protect residents and businesses.

Goal LU-1: Protect and enhance the public safety, health, and welfare of Borough residents.

Policy LU1-1: Provide for consistent, compatible, effective, and efficient development within the Borough.

**RECOMMENDATION OF ADMINISTRATION:** Refer to Planning Commission and then introduce and set for public hearing.

## CHAPTER 17.73: MULTIFAMILY DEVELOPMENT DESIGN STANDARDS

### Section

#### Article I. Adoption

[17.73.010 Title](#)

[17.73.020 Intent and purpose](#)

[17.73.030 Application of provisions](#)

[17.73.040 Density](#)

#### Article II. Application Requirements

[17.73.050 Approval required](#)

[17.73.055 Mobile home parks prohibited](#)

[17.73.060 Administrative review](#)

[17.73.070 Planning commission review](#)

[17.73.080 Appeals process](#)

[17.73.090 Conflicting provisions](#)

[17.73.095 Domestic wastewater system plan](#)

[17.73.100 Nonstructural fire and life safety plan review](#)

[17.73.110 Violation and enforcement](#)

#### Article III. Incentives

*17.73.120 Earning incentive points [Repealed]*

#### Article IV. Standards

[17.73.130 General design standards](#)

*17.73.140 Height [Repealed]*

[17.73.150 Access roads; Design/parking](#)

17.73.160 *Bicycle storage/parking [Repealed]*

[17.73.170 Lighting](#)

[17.73.180 Pedestrian circulation](#)

[17.73.190 Landscaping](#)

[17.73.200 Service area screening](#)

17.73.210 *Fencing and walls [Repealed]*

17.73.220 *Useable open space [Repealed]*

17.73.230 *Mixed use opportunities [Repealed]*

17.73.240 *Affordable housing [Repealed]*

Article V. Definitions

[17.73.250 Definitions](#)

**ARTICLE I. ADOPTION**

**17.73.010 TITLE.**

(A) This chapter shall be known and cited as the “multifamily development design standards ordinance of the Matanuska-Susitna Borough.”

(Ord. 12-169, § 2 (part), 2013; Ord. 06-188(SUB), § 2 (part), 2007)

**17.73.020 INTENT AND PURPOSE.**

(A) The overall goals of this chapter are to provide safe, affordable multifamily developments that promote a healthy lifestyle in the Matanuska-Susitna Borough (also referred to as “borough”). Also, this chapter encourages compatible multifamily development with surrounding land uses, and provides development incentives to encourage innovative multifamily development and affordable housing. Issues related to multifamily development, such as water quality, traffic impacts, design standards, and other associated concerns, are addressed by this chapter. This chapter establishes appropriate density levels for multifamily development throughout the borough.

(Ord. 12-169, § 2 (part), 2013; Ord. 08-018(SUB), § 2, 2008; Ord. 06-188(SUB), § 2 (part), 2007)

**17.73.030 APPLICATION OF PROVISIONS.**

(A) This chapter applies to all multifamily developments, including substandard dwellings, which meet or exceed the density threshold of this chapter, regardless of the form of ownership. This chapter applies to:

- (1) all new multifamily developments started after the effective date of the ordinance codified in this chapter.
- (2) all structural additions totaling 300 square feet and greater to an existing multifamily development.

(B) The provisions of this chapter are not applicable and may not be used for multifamily developments or buildings within the cities of Houston, Palmer, or Wasilla.

(C) The provisions of this chapter are the responsibility of the developer.

(Ord. 12-169, § 2 (part), 2013; Ord. 08-018(SUB), §§ 3, 4, 2008; Ord. 07-058, § 1, 2007; Ord. 06-188(SUB), § 2 (part), 2007)

**17.73.040 DENSITY.**

(A) Density thresholds are used by this chapter to determine if the chapter applies. The density thresholds are determined using the following subsections:

- (1) Residential development constructed at a density greater than two dwelling units per 40,000 square feet of lot area; or
- (2) Any development exceeding six dwelling units, regardless of lot size.
- (3) This chapter shall apply to substandard dwellings offered for compensation in the form of money, services, or barter that are constructed at a density:
  - (a) equal to or greater than one dwelling per 40,000 square feet of lot area, calculated at 0.000025 multiplied by the lot area; and
  - (b) exceeding two dwellings regardless of lot size.

(4) This density threshold does not apply to short-term transient accommodations, as defined by this chapter and subject to regulations by MSB 3.32.010, 3.32.020, and 3.32.030 and subsequent amendments. Short-term transient accommodations shall be exempt from the standards of this chapter.

(B) Density ceiling is the maximum number of dwelling units that can be built per 40,000 square feet. A density ceiling applies when allowed through the application of this chapter and unless otherwise established within a SPUD or another codified standard.

- (1) Two density ceilings are provided.
  - (a) Core Area (As Delineated in the MSB Core Area Comprehensive Plan).
    - (i) The maximum number of dwelling units allowed within the core area is 18 units per 40,000 square feet.
  - (b) Non-Core Area.
    - (i) The maximum number of dwelling units allowed outside of the core area is 12 units per 40,000 square feet.
- (2) Regardless of location, substandard dwellings that are being offered for compensation in the form of money, services, or barter are subject to the following density ceilings:
  - (a) one substandard dwelling per 40,000 square feet; or
  - (b) two substandard dwellings, regardless of lot size.

(Ord. 18-013, § 2, 2018; Ord. 12-169, § 2 (part), 2013; Ord. 08-018(SUB), §§ 5, 6, 2008; Ord. 07-058, § 2, 2007; Ord. 06-188(SUB), § 2 (part), 2007)

## ARTICLE II. APPLICATION REQUIREMENTS

### 17.73.050 APPROVAL REQUIRED.

- (A) Multifamily development permit application approval is required prior to commencement of a multifamily development that meets or exceeds the density threshold of this chapter.
- (B) A complete application includes the following:
  - (1) nonrefundable multifamily development permit fee;
  - (2) three copies of the following documents:
    - (a) permit application;
    - (b) certified site plan (see definition);
      - (i) The landscape and drainage plans may be included as part of the certified site plan;
    - (c) *[Repealed by Ord. 12-169, § 2, 2013]*

(d) drainage plan;

(3) *[Repealed by Ord. 12-169, § 2, 2013]*

(4) additional information as determined by the director.

(Ord. 12-169, § 2 (part), 2013; Ord. 08-018(SUB), § 7, 2008; Ord. 07-058, § 3, 2007; Ord. 06-188(SUB), § 2 (part), 2007)

**17.73.055 MOBILE HOME PARKS PROHIBITED.**

(A) In accordance with the substandard dwelling density limits of MSB [17.73.040\(B\)\(2\)](#), mobile home parks are prohibited.

(B) Mobile home parks in existence as of the date of the adoption of this section are allowed to continue if they:

(1) Were permitted under former MSB 17.48 before August 6, 2024; or

(2) Receive legal nonconforming status under MSB 17.80 by on or before June 30, 2025.

(Ord. 24-096, § 2, 2024)

**17.73.060 ADMINISTRATIVE REVIEW.**

(A) Each application for multifamily development will be approved administratively, unless a variance or other modification to the standards of this chapter is requested.

(B) The planning and land use director or designated staff shall determine whether an application for a multifamily permit is complete. An incomplete application shall be returned to the applicant with a written explanation of application deficiencies within seven working days of the date the application is received in the planning and land use department.

(C) Decisions will be rendered within ten working days from the date the application is determined complete.

(D) The director may revoke any approved application if the development does not conform to the approved application.

(E) If the proposed multifamily development contains or will contain any substandard dwellings offered for commercial compensation in the form of money, services, or barter, and if the minimum criteria for a multifamily development permit are met, the director will notify surrounding property owners in accordance with MSB 17.03, Public Notification. Within 30 days of acceptance of the completed application, the director shall issue a decision on the application with conditions to address concerns raised by surrounding property owners within the notification area, if deemed appropriate by the director.

(Ord. 12-169, § 2 (part), 2013; Ord. 06-188(SUB), § 2 (part), 2007)

**17.73.070 PLANNING COMMISSION REVIEW.**

(A) In the event the applicant wishes to vary from any of the standards of this chapter, the planning commission may grant variances from the standards contained in this chapter. The planning commission will base its decision on the variance review criteria described in MSB 17.65.

(B) The planning commission may consider comments from the department of emergency services when granting a variance.

(C) The planning commission may require conditions of approval when granting a variance to support the overall objectives of the multifamily standards.

(Ord. 12-169, § 2 (part), 2013; Ord. 08-018(SUB), §§ 8, 9, 2008; Ord. 06-188(SUB), § 2 (part), 2007)

**17.73.080 APPEALS PROCESS.**

(A) The appeal of a decision shall be conducted in accordance with the process outlined in MSB 15.39.

(Ord. 12-169, § 2 (part), 2013; Ord. 07-058, § 4, 2007; Ord. 06-188(SUB), § 2 (part), 2007)

**17.73.090 CONFLICTING PROVISIONS.**

(A) If any provisions of this chapter are inconsistent with one another or if they conflict with provisions found in other adopted borough, state, federal, or local codes, ordinances, or regulations, the more restrictive provision will apply.

(Ord. 12-169, § 2 (part), 2013; Ord. 06-188(SUB), § 2 (part), 2007)

**17.73.095 DOMESTIC WASTEWATER SYSTEM PLAN.**

(A) *[Repealed by Ord. 21-013, § 2, 2021]*

(B) Certification by a professional engineer, who is authorized to engage in that profession by the state of Alaska, must be submitted to the planning and land use department within 90 days of installation of the domestic wastewater system, certifying that the domestic wastewater system was installed in full compliance with all applicable Alaska State Department of Environmental Conservation regulations.

(Ord. 21-013, § 2, 2021; Ord. 18-013, § 3, 2018)

**17.73.100 NONSTRUCTURAL FIRE AND LIFE SAFETY PLAN REVIEW.**

(A) All multifamily dwellings:

- (1) shall comply with current Alaska State Fire Code;

(2) may be subject to a nonstructural fire and life safety plan review before construction may begin;

(3) *[Repealed by Ord. 07-058, § 5, 2007]*

(B) *[Repealed by Ord. 07-058, § 5, 2007]*

(C) *[Repealed by Ord. 07-058, § 5, 2007]*

(D) *[Repealed by Ord. 07-058, § 5, 2007]*

(E) *[Repealed by Ord. 07-058, § 5, 2007]*

(F) The following design standards shall be required:

(1) Separation distances between habitable buildings shall be no less than 20 feet, unless approved by the State Fire Marshal or the local fire marshal where a state deferment exists;

(2) *[Repealed by Ord. 12-169, § 2, 2013]*

(3) Hard-wired smoke and carbon monoxide detectors shall be installed in all multifamily dwellings.

(Ord. 12-169, § 2 (part), 2013; Ord. 08-018(SUB), § 10, 2008; Ord. 07-058, § 5, 2007; Ord. 06-188(SUB), § 2 (part), 2007)

#### **17.73.110 VIOLATION AND ENFORCEMENT.**

(A) Except as otherwise specified in this chapter, violations of this chapter are infractions.

(B) Remedies, enforcement actions, and penalties shall be consistent with the terms and provisions of MSB 1.45.

(Ord. 12-169, § 2 (part), 2013; Ord. 06-188(SUB), § 2 (part), 2007)

### **ARTICLE III. INCENTIVES**

**17.73.120 EARNING INCENTIVE POINTS. [Repealed by Ord. 12-169, § 2, 2013]**

### **ARTICLE IV. STANDARDS**

#### **17.73.130 GENERAL DESIGN STANDARDS.**

(A) *[Repealed by Ord. 12-169, § 2, 2013]*

(1) No more than 60 percent of the lot area shall be occupied by impervious surface areas;

(2) *[Repealed by Ord. 12-169, § 2, 2013]*

(3) *[Repealed by Ord. 07-058, § 7, 2007]*

(4) *[Repealed by Ord. 12-169, § 2, 2013]*

(5) Comply with Americans with Disabilities Act of 1990 (ADA) Requirements. In addition to ADA, all buildings exceeding four units must comply with all of the Fair Housing Act of 1968 requirements;

(6) *[Repealed by Ord. 12-169, § 2, 2013]*

(7) *[Repealed by Ord. 12-169, § 2, 2013]*

(8) Perimeter setbacks are the minimum required yards measured from the perimeter property lines or public access easement(s), whichever is the more restrictive. The following perimeter setbacks apply:

(a) front: 25 feet;

(b) rear: 20 feet; and

(c) side: ten feet;

(9) *[Repealed by Ord. 12-169, § 2, 2013]*

(10) Minimum interior setbacks are measured between habitable buildings, detached garages, and other detached accessory buildings.

(a) *[Repealed by Ord. 12-169, § 2, 2013]*

(b) detached garages: ten feet; and

(c) other detached nonhabitable accessory buildings: ten feet;

(11) *[Repealed by Ord. 12-169, § 2, 2013]*

(12) Roof overhangs may project from the outside wall no more than two feet into the setback, and are not considered as part of the setback.

(Ord. 12-169, § 2 (part), 2013; Ord. 08-018(SUB), §§ 12, 13, 2008; IM 07-289, page 2 (part), presented 11-13-07; Ord. 07-058, § 7, 2007; Ord. 06-188(SUB), § 2 (part), 2007)

**17.73.140 HEIGHT. *[Repealed by Ord. 12-169, § 2, 2013]***

**17.73.150 ACCESS ROADS; DESIGN/PARKING.**

(A) All primary vehicle access to a multifamily development, at a minimum, shall be from a residential road as described by the borough's Subdivision Construction Manual;

(B) The following standards shall apply:

(1) Vehicle Access and Circulation.

(a) Any multifamily developments exceeding the thresholds of MSB 17.61.050 will submit a traffic impact analysis (TIA) as directed;

(b) The director has the authority to restrict or require additional access to the development when the need to do so is dictated by one or more of the following conditions:

(i) the development causes or increases hazardous traffic conditions; or

(ii) there is inadequate access provided for emergency vehicles; or

(iii) the development causes hazardous conditions to exist which would constitute a clear and present danger to the public health, safety, and general welfare;

(c) To provide for increased traffic movement on congested streets and to eliminate road capacity conflicts, the director may consult with the planning transportation division or the public works department for findings that may restrict the location of driveways or approach roads on streets and require the location of driveways and approach roads to be placed on adjacent streets, or in a new location;

(2) *[Repealed by Ord. 08-018(SUB), § 16, 2008]*

(3) Multifamily residential developments shall not have primary access to an arterial street(s), unless approved by the appropriate governing entity; and

(4) The internal drive system will connect to the perimeter public street system to provide for inter-connectivity with public amenities, adjoining neighborhoods, and adjacent developments; and

(5) For emergency service purposes, all internal drive systems shall conform to MSB 11.20 and be named.

(C) Street Design.

(1) Street design shall minimize automobile and pedestrian conflicts and strive to create low-profile, safe, modest parking areas. All public street design standards shall comply with the borough's Subdivision Construction Manual. The following standards shall apply:

(a) The development's street design shall create a hierarchy of streets and drives for the development. To the extent possible, the design of all through-access drives shall be consistent with, and aligned with, residential drives or through-access drives in adjacent existing or planned development sites.

(D) Private Access Drives.

(1) Minimum private access drive width must be no less than 20 feet in width.

(a) For road design and access standards, see the borough's Subdivision Construction Manual.

(b) Parking along private access drives is prohibited unless designed to accommodate the standards of this chapter.

(E) Parking Standards. Minimum parking spaces required per dwelling unit:

(1) efficiency unit: 1.0 per dwelling unit;

(2) one- to two-bedroom units: 1.5 per dwelling unit; and

(3) three- or more bedroom units: 2.0 per dwelling unit.

(F) Vehicle Parking Space Design Requirements.

(1) Standard:

(a) length: 20 feet;

(b) width: ten feet; and

(c) vertical clearance: seven feet;

(2) Barrier-free (ADA):

(a) one barrier-free parking stall shall be provided for every 25 required parking stalls.

(i) width: eight feet plus a five-foot adjacent access aisle;

(ii) length: 20 feet; and

(iii) vertical clearance: eight feet.

(Ord. 12-169, § 2 (part), 2013; Ord. 08-018(SUB), § 16, 2008; Ord. 07-058, § 8, 2007; Ord. 06-188(SUB), § 2 (part), 2007)

**17.73.160 BICYCLE STORAGE/PARKING. [Repealed by Ord. 12-169, § 2, 2013]**

**17.73.170 LIGHTING.**

(A) Lighting standards provide visual safety in high traffic areas within the development while preventing excessive lighting and glare on adjacent properties.

(B) Exterior lighting shall comply with the following standards:

- (1) Pedestrian pathways must have adequate lighting with increased illumination around building entrances and transit stops.
- (2) All parking areas exceeding 18 on-site parking stalls must have adequate lighting.
- (3) Lights in parking lots must be non-glare and must be mounted no more than 20 feet above the ground.
- (4) *[Repealed by Ord. 12-169, § 2, 2013]*
- (5) Glare and illumination associated with exterior lighting shall be contained on the subject property and not impact adjacent properties.

(Ord. 12-169, § 2 (part), 2013; Ord. 06-188(SUB), § 2 (part), 2007)

**17.73.180 PEDESTRIAN CIRCULATION.**

(A) *[Repealed by Ord. 12-169, § 2, 2013]*

(B) On-site pedestrian paths shall comply with the following standards:

- (1) *[Repealed by Ord. 12-169, § 2, 2013]*
- (2) *[Repealed by Ord. 12-169, § 2, 2013]*
- (3) within all multifamily developments, each residential building will be connected by a path to the vehicular parking area;
- (4) crossings shall be designed and located for pedestrian safety wherever required pedestrian paths intersect with vehicle access driveways or parking lots;
- (5) required paths shall be paved with hard surface materials as defined in the most recent version of the ADA Standards for Accessible Design; and

- (6) path widths shall be no less than five feet.

(Ord. 12-169, § 2 (part), 2013; Ord. 07-058, § 9, 2007; Ord. 06-188(SUB), § 2 (part), 2007)

**17.73.190 LANDSCAPING.**

(A) *[Repealed by Ord. 12-169, § 2, 2013]*

(B) Landscaping. The existing natural landscape, especially healthy plants, shrubs, and trees indigenous to the area, should be preserved to an extent that is reasonable and feasible. Further, if it is not prudent to retain existing vegetation or no existing vegetation exists, the site shall be designed to accommodate landscaping. The following landscaping standards apply:

- (1) Landscape Plan.

- (a) The applicant's proposed landscape plan will indicate the project's compliance with these standards.

- (2) Plant Materials.

- (a) Retain, at a minimum, 10 percent of the existing ground cover, natural plant species, and healthy tree canopy of the lot, including the understory and foliage; or

- (b) Install landscaping for 10 percent of the area within a 100-foot radius of each structure on the property. Installed landscaping shall be:

- (i) a species known to reach a minimum height of at least three feet and tolerant of the climate zone; and

- (ii) established within two years of the project's application.

- (3) Perimeter Landscaping.

- (a) The perimeter(s) of the subject development adjacent to developed or developable properties, other than a street edge, require a perimeter landscape buffer.

- (i) Vegetation used for the perimeter buffers shall be, at a minimum, three feet in height at the time of installation.

- (ii) Vegetation used for the perimeter buffers shall be species known to reach a minimum height of six feet and tolerant of the local climate zone.

- (b) Perimeter buffers shall be landscaped with a combination of evergreen trees or shrubs at a ratio

of one per 40 linear feet of edge, measured on center. Fractional requirements will be rounded up.

(c) All perimeter landscaping located on corner lots shall be located and maintained so as not to obstruct vehicular/driver visibility in accordance with the American Association of State Highway and Transportation Officials (AASHTO) standards.

(d) Exception. If the application has multiple lots that will be part of one large multifamily development, perimeter landscaping is only required around the perimeter of the overall development area.

(4) Perimeter Fences and Walls.

(a) A perimeter fence or wall is not required but may be installed. If a perimeter fence or wall is installed, in addition to the perimeter landscaping, then the following standards apply:

(i) walls and fences shall be constructed of high-quality materials, such as treated wood, decorative blocks, brick, stone, wrought iron, chain link, and other natural and appropriate building materials.

(Ord. 12-169, § 2 (part), 2013; Ord. 07-058, § 10, 2007; Ord. 06-188(SUB), § 2 (part), 2007)

**17.73.200 SERVICE AREA SCREENING.**

(A) Service areas often create noise and visual impacts on adjacent uses and neighborhoods. The following standards visually screen on-site service areas, including trash collection areas, from public rights-of-way and adjacent properties;

(B) Trash containers and collection areas must be oriented away from public streets or adjacent property lines;

(C) Trash collection areas will be located a minimum of 20 feet from any adjacent property line;

(D) Trash containers must be secured from the effects of wind; and

(E) Trash containers and collection areas will be screened using any of the following methods:

(1) fence or wall at least five feet in height;

(2) one three-foot-wide row of vegetation screening, using vegetation at least five feet in height; or

(3) any combination of the above.

(Ord. 12-169, § 2 (part), 2013; Ord. 07-058, § 11, 2007; Ord. 06-188(SUB), § 2 (part), 2007)

**17.73.210 FENCING AND WALLS. [Repealed by Ord. 12-169, § 2, 2013]**

**17.73.220 USEABLE OPEN SPACE. [Repealed by Ord. 12-169, § 2, 2013]**

**17.73.230 MIXED USE OPPORTUNITIES. [Repealed by Ord. 12-169, § 2, 2013]**

**17.73.240 AFFORDABLE HOUSING. [Repealed by Ord. 18-013, § 4, 2018]**

## ARTICLE V. DEFINITIONS

### 17.73.250 DEFINITIONS.

(A) For purposes of this chapter, the following definitions shall apply. All other definitions are listed in MSB 17.125, Definitions.

- “Developer” means the legal or beneficial owner or owners of a lot or of any land included in a proposed multifamily development.
- “Dwelling unit” means a single unit providing complete, independent living facilities for one or more persons, including permanent provisions for living, sleeping, eating, cooking, and sanitation or a portion of the land area of a planned development, residential development or site condominium project designed and intended for residential construction.
- “Grade plane” means a reference plane representing the average of finished ground level adjoining the building at exterior walls. Where the finished ground level slopes away from the exterior walls, the reference plane shall be established by the lowest points within the area between the building and the lot line or, where the lot line is more than six feet (1,829 mm) from the building, between the building and a point six feet (1,829 mm) from the building.
- “Height, building” means the vertical distance from grade plane to the average height of the highest roof surface.
- “Mobile home” means a detached single-family dwelling designed for long-term human habitation and having complete living facilities; capable of being transported to a location of use on its own chassis and wheels; identified by a model number and serial number by its manufacturer, and designed primarily for placement on a nonpermanent foundation.
- “Mobile home parks” means any parcel, tract or lot or portion thereof where more than two mobile homes or travel trailers are leased, rented, or held for rent for occupancy, but not including automobile or trailer sales lots on which unoccupied mobile homes are parked for inspection and sale or camper parks in which travel trailers are permitted for temporary occupancy of less than 30 days.
- “Substandard dwelling” means:
  - (1) a structure used for human habitation, including a structure mounted on skids or wheels, which

lacks one or more of the following:

- (a) permanent foundations; or
  - (b) water plumbed to run within the dwelling; or
  - (c) meets the standards of the Alaska State Department of Environmental Conservation wastewater and septic systems.
- “Travel trailers” means a motor vehicle or portable vehicular structure capable of being towed on the highways by a motor vehicle designed or intended for casual or short-term human occupancy for travel, recreational or vacation uses, identified by a model number, serial number or vehicle registration number, equipped with limited water storage and other self-contained living facilities.

(Ord. 24-096, §§ 3, 4, 2024; Ord. 18-013, § 5, 2018; Ord. 12-169, § 3, 2013; Ord. 08-018(SUB), § 17, 2008)

**CHAPTER 17.125: DEFINITIONS**

Section

**17.125.005 General provisions****17.125.010 Definitions****17.125.005 GENERAL PROVISIONS.**

(A) The definitions listed in this section shall apply to the words and phrases used in MSB Title 17 unless otherwise described within the individual chapters.

- (1) Words used in the present tense shall include the future.
- (2) Words in the singular number shall include the plural number and the plural number shall include the singular.
- (3) The word “shall” is mandatory.
- (4) The words “include,” “including,” and “includes” shall be interpreted as being followed by the phrase “but not limited to.”
- (5) The word “lot” includes the words “plot” and “parcel.”

(B) In instances where a word is not included in this section nor in the applicable section, reference will be made first to the most recent publication of “The Illustrated Book of Development Definitions” then to “The Zoning Dictionary” by Lehman and Associates, then to “Webster’s New Universal, Unabridged Dictionary.”

(Ord. 05-125(SUB)(AM), § 2 (part), 2005)

**17.125.010 DEFINITIONS.**

- “Access” means a legal way or means of approach to provide physical ingress or egress to a property.
- “Accessory building” means a building detached from a principal building located on the same lot and customarily incidental and subordinate to the principal building or use.
- “Accessory use” means a use or structure incidental and subordinate to the principal use or structure on a parcel of land, is on the same parcel as the principal use or structure, and is a use or structure commonly associated with the principal use or structure and integrally related to it. Some examples are: private garages or storage sheds on residential property or barns on agricultural property.
- “Administrative permit” means a written document issued administratively which may specify controls,

restrictions and safeguards on the administratively permitted activity to ensure compatibility with permitted uses.

- “Adult bookstore” means a commercial establishment where at least 51 percent of its interior floor area or retail merchandise is devoted to the sale, rent, lease, inspection, or viewing of books, films, video cassettes, magazines, or other media or periodicals whose dominant theme is actual or simulated specified sexual activities, display or exhibition of specified anatomical areas, removal of articles of clothing, or total nudity.
- “Adult business” means any bookstore, adult cabaret, adult escort service, adult massage service, adult mini-theater, or adult motion picture theatre.
- “Adult cabaret” means a restaurant, coffee house, or cabaret which features topless dancers, strippers, male or female impersonators, or similar entertainers who provide live adult entertainment for commercial purposes at any time or any number of times.
- “Adult entertainment” means any motion picture, live performance, display, or dance of any type whose dominant theme is actual or simulated specified sexual activities, display or exhibition of specified anatomical areas, removal of articles of clothing, or total nudity, whether live or by shadow effects, offered for commercial purposes.
- “Adult escort” means a person who, for monetary consideration such as a fee or tip, or for other non-monetary consideration, agrees or offers to act as a companion, guide, or date that may provide services such as modeling lingerie, adult entertainment, adult massage service, or similar activities.
- “Adult escort service” means a person or business that, for monetary consideration such as a fee or tip, or for other non-monetary consideration, furnishes or offers adult escorts.
- “Adult massage service” means a person or business that, for monetary consideration such as a fee or tip, or for other non-monetary consideration, furnishes or offers massages or related services, for which the service providers do not have a license for the practice of that profession or vocation as regulated under Alaska Statute Title 8, or which also provides adult entertainment.
- “Adult mini-theater” means an enclosed building with a capacity of less than 50 persons used for the purpose of displaying adult entertainment through films, video, or other motion pictures for commercial purposes.
- “Adult motion picture theater” means an enclosed building with a capacity of 50 or more persons used for the purpose of displaying adult entertainment through films, video, or other motion pictures for commercial purposes.
- “Adverse impact” means a condition that creates, imposes, aggravates, or leads to inadequate, impractical, unsafe, or unhealthy conditions on a site proposed for development or on other properties and facilities.
- “Affordable housing” means housing renting for monthly rent of not more than 30 percent of the total monthly

household income of low income households (defined to be household earnings less than 80 percent of the median annual income adjusted for household size, as determined by the United States Housing and Urban Development Department); or housing that may be purchased with monthly payments including: principal, interest, taxes, insurance, homeowner association fees, and assessments that do not add up to more than 30 percent of the total monthly household income of low income households.

- “Agricultural” means the production and harvest or care of plants, animals, birds, fish, bees, and other organisms by humans for use in providing food, fuel, fiber, shelter, travel, clothing, energy, and aesthetics.
- “Allowed use” means a use of land or a structure, which is permissible by right or condition within a certain zoning district according to the regulations of this code.
- “Amateur radio tower” means any tower used for amateur radio transmissions consistent with the “Complete Federal Communications Commission U.S. Amateur Part 97 Rules and Regulations” for amateur radio facilities.
- “Americans with Disabilities Act (ADA)” means a 1990 federal law designed to bring disabled Americans into the economic mainstream by providing them equal access to jobs, transportation, public facilities, and services.
- “Ancillary structure” means any form of development associated with a telecommunication facility, including but not limited to: foundations, concrete slabs on grade, guy wires, guy anchors, generators, and transmission cable supports; however, specifically excluding equipment cabinets.
- “Angle of repose” means the steepest angle material can be piled without slumping.
- “Antenna” means any apparatus designed for the transmitting or receiving of electromagnetic waves. Types of antenna include, but are not limited to: omni-directional antennas, directional antennas, multi or single bay, yagi, or parabolic antennas.
- “Applicant” means a person or authorized representative submitting an application for development.
- “Aquifer” means a formation, a group of formations, or part of a formation that contains sufficient saturated permeable material to yield economical quantities of water to wells and springs.
- “Batch plant” means a plant or equipment used for production of asphalt or concrete.
- “Bedroom” means a private room planned and intended for sleeping, separated from other rooms by a door, and accessible to a bathroom without crossing another bedroom.
- “Berm” means an earthen mound designed to provide visual interest, screen undesirable views, decrease noise, or control or manage surface drainage.

- “Bioswales” means open channels that usually possess a dense cover of grasses and other herbaceous plants through which runoff is directed during storm events. Bioswales allow runoff to infiltrate.
- “Breakpoint technology” means the engineering design of a tower wherein a specified point is designed to have stresses concentrated so that the stress point is at least 5 percent more susceptible to failure than any other point along the structure. In the event of a structural failure, the failure will occur at the breakpoint rather than at the base plate, anchor bolts, or any other point on the tower.
- “Broadcast facilities” means a tower, antennas, or antenna arrays for FM/TV/HDTV broadcasting transmission facilities, and tower(s) utilized as antennas for an AM broadcast station that are licensed by the Federal Communications Commission.
- “Buffer” means a method of protection against negative impacts, which provides a physical separation or barrier.
- “Building” means any structure, including mobile homes, intended for the shelter, housing, or enclosure of any person, animal, process, equipment, goods, use, materials, or services of any kind or nature.
- “Cabin” means any residential building no greater than 800 square feet in gross floor area.
- “Capture area” means the area on the surface of the ground where infiltrating water will travel to a drinking water well.
- “Caretaker” means a person(s) who takes care of land, dwellings, animals, or belongings when an owner is absent.
- “Certified site plan” means a site plan that is prepared and sealed by an architect, professional engineer or land surveyor, authorized to engage in that profession by the state of Alaska. The certified site plan shall be at a scale of one inch equals 50 feet (or less) showing dimensions and locations of all existing and proposed development on the site in relationship to all property lines.
- “Character” means those attributes, qualities, and features that make up and distinguish a development project and give such project a sense of purpose, function, definition, and uniqueness.
- “Circulation” means systems, buildings, and physical improvements for the movement of people, goods, water, air, sewage, or power by such means as streets, highways, railways, waterways, and airways.
- “Collocation” means the installation of antennas and associated equipment from more than one provider on a single structure.
- “Commencement of construction or placement” means the first placement of permanent construction of a

building on a site, such as the pouring of a slab or footings, the installation of piles, the construction of columns, or any work beyond the stage of excavation; or the placement of a building upon a foundation.

- “Commercial use” means a land use, business enterprise, or vehicle maintained for the purpose of buying or selling goods or services.
- “Commission” means the Matanuska-Susitna Borough Planning Commission.
- “Compatible design” means the visual relationship between adjacent and nearby buildings and the immediate streetscape, in terms of a consistency of materials, colors, building height, building elements, building mass, and other constructed elements of the urban environment, such that abrupt or severe differences are avoided.
- “Conditional use” means a use of a structure or land, which may be allowed by the planning commission after a public hearing and review and subject to certain prescribed or imposed conditions.
- “Conditional use permit (CUP)” means a written document which may specify controls, restrictions and safeguards on the conditional permitted activity to ensure compatibility with permitted uses.
- “Conditions of approval” means requirements established by the borough before preliminary or final approval of an application becomes effective.
- “Confined aquifer” means an aquifer which is bounded above and below by formations of impermeable or relatively impermeable material. An aquifer in which ground water is under significantly greater pressure than atmospheric pressure and its upper limit is the bottom of a bed of distinctly lower hydraulic conductivity than that of the aquifer itself. Confined aquifer is synonymous with artesian aquifer.
- “Confining layer” means a geologic bed or layer that retards but does not necessarily prevent the flow of water. A confining layer does not readily yield water to wells or springs. Confining layer is synonymous with aquitard.
- “Contiguous acres” includes acreage that may be separated by a highway or railroad.
- “Deciduous” means plants that drop their foliage annually before becoming dormant.
- “Density” means the number of dwelling units allowed per area of a development site or parcel.
- “Design standards” means a set of regulations defining parameters to be followed in site and building design and development.
- “Designee” means the director or his/her duly authorized representative.
- “Developer” means the legal or beneficial owner or owners of a lot or of any land included in a proposed

development, including the holder of an option or contract to purchase or other persons having enforceable proprietary interests in such lands.

- “Development” means the construction, reconstruction, conversion, structural alteration, relocation, placement, or enlargement of any building.
- “Director” means the director of planning and land use.
- “Dog mushing” means a transport method powered by one or more dogs for sport or paid service.
- “Drainage plan” means a plan that is prepared and stamped by a civil engineer authorized to operate in the state of Alaska, which contains the following:
  - (a) background information:
    - (i) project description;
    - (ii) existing (predevelopment) conditions; and
    - (iii) proposed future (development) conditions.
- “Duplex” means a structure containing two dwelling units, each of which has direct access to the outside.
- “Dwelling unit” means one or more rooms, providing complete, independent living facilities for one or more persons, including permanent provisions for living, sleeping, eating, cooking, and sanitation.
- “Earth materials” includes those natural resources such as sand, rock, gravel, soil, peat moss, sphagnum, stone, pumice, cinders and clay; also called “materials.”
- “Earth materials processing” means any crushing, loading, screening, sorting, storing, washing, or production of asphalt.
- “Efficiency” means a one-room unit that serves as the occupant’s total living, sleeping, and eating space, usually containing a separate bathroom.
- “Egress” means an exit.
- “Equipment compound” means the area occupied by a tower including areas inside or under the following: an antenna-support structure’s framework, equipment cabinets, and ancillary structures.
- “Evergreen” means vegetation that has foliage that persists and remains green throughout the year.

- “Extraction” means to take and remove earth materials from the subject site to an off-site location.
- “Fair Housing Act of 1968” means that Title VIII of the Civil Rights Act of 1968 (Fair Housing Act), as amended, which prohibits discrimination in the sale, rental, and financing of dwellings, and in other housing-related transactions, based on race, color, national origin, religion, sex, familial status, and handicap (disability).
- “Feed lines” means cables used as the interconnecting media between the transmission or receiving equipment and the antenna.
- “Fence” means a manmade barrier of any material or combination of materials erected to enclose, screen, or separate areas.
- “Fence, solid” means a fence, including any gates, constructed of solid material, wood, or masonry, through which no visual images may be seen.
- “Fire service area” means a geographic region or area established by the borough to provide fire stations and related facilities or services that are needed to protect the health, safety, or welfare of persons and property within that area.
- “Flag lot” means a lot with a long, narrow strip protruding from one side (pole) which fronts on a borough standard width legal right-of-way and provides access to the lot.
- “Garage” means an accessory building or portion of a main building primarily used for storage of motor vehicles. A “garage” is distinguished from a “carport” in that a garage is enclosed on more than three sides, so that the stored or parked car is contained entirely inside the building.
- “Ground cover” means grasses or other low-growing plants and landscaping.
- “Groundwater” means that part of the subsurface where water occurs in the saturated zone.
- “Habitable” means a residence that is safe and can be occupied in reasonable comfort; the premises should be closed in against the weather, provide running water, access to decent toilets and bathing facilities, heating, and electricity. Particularly in multifamily developments, freedom from noxious smells, noise, and garbage are expected.
- “Heavy industrial” means the use of land, buildings, or structures for the manufacturing, processing, fabricating, or assembly of raw materials, warehousing or bulk storage of goods, and related accessory uses.
- “Height, building” means the height of a building, the vertical distance as measured from the base of the building at finished grade to the highest point of the building including appurtenances. The average between the highest and lowest grades within 20 feet of the building shall be considered finished grade and be used in

calculating the height.

- “Height, tall structure” means the vertical distance measured from finished grade to the highest point of the tall structure, not including appurtenances, antennas, or equipment affixed thereto. In the case of wind energy conversion systems, the blade is considered part of the overall height of the structure.
- “Historical uses” means lands with sites, structures, landmarks, or objects with local, regional, statewide, or national historical significance that have been used by past populations for historic or traditional uses (such as subsistence activities, trail use, etc.) and that are often currently enjoyed by users.
- “Impermeable” means a surface or material that provides a functional barrier to significant liquid flow or infiltration.
- “Impervious area/surface” means the area of the subject site covered by impenetrable materials. This surface has been compacted or covered with a layer of material so that it is highly resistant to infiltration by water.
- “Incentive points” means numerical points that are provided to applicants that exceed the required minimum design standards.
- “Industrial use” means any activity which includes manufacturing, processing, warehousing, storage, distribution, shipping, or other related uses.
- “Ingress” means access or entry.
- “Isochron” means a line drawn on a map through all points having the same numerical value of time.
- “Junkyard/refuse area” means a location which is commercially used for the purpose of the outdoor storage, handling, dismantling, wrecking, keeping or sale of used, discarded, wrecked or abandoned airplanes, appliances, vehicles, boats, building and building materials, machinery, equipment, or parts thereof, including, but not limited to, scrap metals, wood, lumber, plastic, fiber, or other tangible materials.
- “Landfill” means an area in which solid waste is disposed of on or into the land, or that portion of a facility where landfilling is taking or has taken place. “Landfill” does not include a landspreading facility or a containment structure used for the disposal of drilling wastes.
- “Landscape plan” means a plan, drawn to scale, showing proposed location and type of existing vegetation to be retained, and proposed new vegetation. The landscape plan may be a component of the certified site plan. Landscape plans shall also include:
  - (a) proposed grade changes;

(b) proposed buffers; and

(c) proposed screening devices.

- “Landscaping” means any of the following or combination of material such as, but not limited to, grass, natural ground cover, shrubs, flowers, vines, hedges, trees, indigenous plant materials, planters, brick, stone or natural forms, water forms, but not including the use of smooth concrete or asphalt.
- “Large-scale commercial” means a commercial building whose total gross building area, including outdoor display and sales area, is equal to or exceeds 25,000 square feet. Large-scale commercial does not include agricultural uses or activities.
- “Legal trail” means a trail that has been legally dedicated for public use either in fee simple or as a public use easement as a trail. The trail has an existing right-of-way or formal, written and recorded landowner permission allowing public access along its entire length.
- “Livable space” means the square footage of habitable or living areas in a building intended for occupancy by one or more persons for living or sleeping quarters.
- “Livestock” means outdoor animals (i.e., cows, goats, horses, pigs, sled dogs, barnyard fowl, etc.) kept for the purpose of providing food, clothing, work or recreation.
- “Living area” means an area or room(s) in a building designed for occupancy by one or more persons for living or sleeping quarters.
- “Lot” means the least fractional part of subdivided lands having limited fixed boundaries and having an assigned number, or other name through which it may be identified.
- “Lot area” means the total horizontal area within the lot lines of a lot, but does not include the pole area of a flag lot and excludes any street rights-of-way.
- “Maintenance” means the servicing, repairing, or altering of any premises, appliance, apparatus, or equipment to perpetuate the use or purpose for which such premises, appliance, apparatus, or equipment was originally intended.
- “Mixed use development” means the development of a neighborhood, tract of land, building with a variety of complementary and integrated uses, such as, but not limited to, residential, office, neighborhood commercial, retail, public, recreation, in a compact urban form.
- “Monitoring well” means any cased excavation or opening into the ground made by digging, boring, drilling, driving, jetting or other methods for the purpose of determining the physical, chemical, biological, or radiological

properties of groundwater.

- “Multifamily” means any development that exceeds the density thresholds within MSB 17.73.040(A).
- “Natural features” means, but is not limited to, floodplains and surface drainage channels, stream corridors, wetlands and riparian habitat, wildlife and scenic corridors, and other bodies of water, steep slopes, prominent ridges, bluffs, or valleys, and existing trees and vegetation.
- “Natural grade” means the elevation of the ground level in its natural state, before construction, filling, or excavation.
- “Neighborhood” means an area of a community with characteristics that distinguish it from other areas and that may include distinct social or economic characteristics, housing types, schools, or boundaries defined by physical barriers such as major highways, and railroads, or natural features such as water bodies or topography.
- “Neighborhood commercial use(s)” means mixed use establishments primarily engaged in the provision of frequently or recurrently needed goods for household consumption, such as prepackaged food and beverages and limited household supplies and hardware. Typical commercial uses include neighborhood convenience stores, laundromats, dry cleaners, small neighborhood offices, postal services, and gas stations.
- “Occupied” means the presence of an individual or individuals in a structure or on a parcel of land or contiguous parcels.
- “Operator or manager” means any natural person responsible for the actual operation and management of an adult business.
- “Ownership interest” in any unincorporated business, means any interest in real or personal property used in connection with the business, coupled with any degree of exercise of management, supervision, direction, or control of the business. In any incorporated business, the term “ownership interest” means ownership of any stock of the corporation.
- “Parcel” means a lot or contiguous group of lots in single ownership or under single control, usually considered a unit for purposes of development.
- “Parking area/lot” means any public or private area, under or outside a building, designed and used for parking motor vehicles, including parking lots, garages, private driveways, and legally designated areas of public streets.
- “Path/pathway” means a cleared way for pedestrians or bicycles that may or may not be improved.
- “Pedestrian walkway” means a walkway or tunnel located at, above, or below grade level that is used as a

means of travel by persons.

- “Permit” means written governmental permission issued by an authorized official, empowering the holder thereof to do some act not forbidden by law but not allowed without such authorization.
- “Pervious hard surface” means any material that permits full or partial absorption of storm water into a previously unimproved land.
- “Phase” means a portion of an operation undertaken in a logical time and geographical sequence.
- “Pollution” means the contamination or other degradation of the physical, chemical or biological properties of water or air, including change in temperature, taste, color, turbidity or odor, or such discharge of any liquid, gaseous, solid, radioactive or other substance into water or air as will or is likely to create a nuisance or render such water or air harmful, detrimental or injurious to public health, safety or welfare, or to domestic, commercial, industrial, agricultural, recreational or other beneficial uses, or to livestock, wild animals, birds, fish or other aquatic life.
- “Primary vehicle access” means, in the context of multifamily development, a vehicle access to the development that is, at a minimum, characterized by the following elements: (1) full-turn vehicle access (i.e., turns allowed in all directions); (2) entryway signage with name of development and address; and (3) principal entry for prospective owners or renters. All public and private roads must meet design standards as outlined in the borough’s subdivision construction manual and addressing/street naming requirements as designated by the borough’s geographic information systems department.
- “Principal use” means the primary or predominant use of any lot, building, or structure.
- “Property” means a lot, parcel, or tract of land together with the building located thereon.
- “Public land” means land owned, maintained, or managed by a public agency.
- “Qualified professional” means a professional hydrologist, geologist, or registered engineer that has specific education and experience with groundwater hydrology.
- “Recreational uses” means the pursuit of leisure-time activities such as, but not limited to, boating, dog mushing, fishing, hunting, trapping, swimming, motorized and nonmotorized activities, sports, games of skill, hiking, skiing, etc., and may include the enjoyment of natural beauty, historic landmarks, or wildlife.
- “Reserved trail” means a trail that has been legally dedicated for public use either in fee simple or as a public use easement as a trail. The trail has an existing right-of-way or formal, written and recorded landowner permission allowing public access along its entire length.

- “Responsible party” means the landowner or the land owner’s designated agent.
- “Residential use” means the use of land, buildings or structures for human habitation.
- “Right-of-way” means a strip of land reserved or dedicated, used or to be used for a street, alley, walkway, trail, airport, or circulation related purpose.
- “Road” means a public or private way that provides access to property for vehicles or pedestrians.
- “Runoff” means the portion of rainfall, melted snow, irrigation water, and any other liquids that flows across the ground surface.
- “Scenic views” means scenic, natural views that may be of significant natural beauty, farmlands, mountains, or other scenes. The goal of development should be to preserve unique vistas and scenic corridors to the greatest extent possible.
- “Screening” means a method of visually shielding or buffering one abutting or nearby building or use from another by fencing, walls, berms, or densely planted vegetation.
- “Seasonal high water table” means the highest level to which the groundwater rises in most years. Estimates are based on observations of the water table at selected sites and on the evidence of a saturated zone, the upper limit often consisting of a mixture of grayish and reddish mottles in the soil.
- “Setback” means the distance between a structure or activity and any lot line, right-of-way, or easement and also the minimum distance required to be maintained between two structures or between a structure and property line, right-of-way, water well, or water body. The distance shall be calculated in a straight line, without regard to intervening structures or objects to the closest exterior point of the structure, property line, or shore line, or center of the well.
- “Short-term transient accommodation” means accommodations for compensation in a building or portions of a building consisting of a residency of any period less than 60 days. If residency exceeds 59 consecutive days, it cannot be considered a short-term transient accommodation for the purposes of this title.
- “Sidewalk” means a paved, surfaced, or leveled area, paralleling and usually separated from the traveled way, used as a pedestrian walk.
- “Single-family dwelling” means a building containing one dwelling unit.
- “Site” means any plot or parcel of land or combination of contiguous lots or parcels of land.
- “Slope” means the rate of vertical change of ground surface expressed as a percentage figure and

determined by dividing the vertical distance by the horizontal distance.

- “Solid waste” means drilling wastes, garbage, refuse, sludge, building material, or other discarded material, including solid, liquid, semi-solid, or contained gaseous material resulting from industrial, commercial, or agricultural operations, or from community activities. For purposes of this chapter, “solid waste” does not include:
  - (a) spoil and overburden from road construction, land clearing, or mining operations;
  - (b) mining waste regulated by federal and state regulations;
  - (c) domestic sewage and other wastes that are discharged into and pass through a sewer system to a publicly owned treatment works;
  - (d) industrial or mining wastes that are being collected, stored, or treated in:
    - (i) a wastewater treatment plant before discharge or removal; or
    - (ii) an industrial processing facility for continual re-use;
  - (e) industrial discharges that are point sources subject to federal or state permits;
  - (f) nuclear or nuclear byproduct material.
- “Specified anatomical areas” means:
  - (a) less than completely and opaquely covered human genitals, pubic region, buttocks, and female breast below a point immediately above the top of the areola; and
  - (b) human male genitals in a discernibly turgid state, even if opaquely covered.
- “Specified sexual activities” means simulated or actual:
  - (a) display of human genitals in a state of sexual stimulation or arousal;
  - (b) acts of masturbation, sexual inter-course, sodomy, bestiality, necrophilia, sado-masochistic abuse, fellatio, or cunnilingus; and
  - (c) fondling or erotic touching of human genitals, pubic region, buttocks, or female breasts.
- “Standards” means mandatory regulations, which are indicated by use of the terms “will,” “shall” and “must.”
- “Steep slopes” means any portion of a development site where the natural grade of the land has a slope of 40

percent or greater.

- “Stream” means a body of flowing water, where the water flows in a natural channel as opposed to a canal.
- “Stream corridor” means the corridor defined by the top of the stream’s channel bank, plus the adjacent land areas that contain vegetation, habitats, and ecosystems associated with bodies of water or dependent on the flow of water in the stream. Biologists often refer to the adjacent land area, which will vary in width depending on the particular stream, as a “riparian ecosystem.” In braided channels, the stream corridor shall include the entire stream feature.
- “Street” means any vehicular way that is (1) an existing state, municipal, or borough roadway; (2) shown upon a plat approved pursuant to law; (3) approved by other official action; (4) shown on a plat duly filed and recorded in the office of the recording clerk; (5) shown on the official map or adopted master plan. It includes the land between the street lines, whether improved or unimproved.
- “Structure” means anything that is constructed or created and located on or under the ground, or attached to something fixed to the ground. For purposes of minimum setbacks and building separation requirements, the following are not considered structures unless specifically addressed by code: fences; retaining walls; parking areas; roads, driveways, or walkways; window awnings; a temporary building when used for 30 days or less; utility poles and lines; guy wires; clotheslines; flagpoles; planters; incidental yard furnishings; water wells; monitoring wells; and/or tubes, patios, decks, or steps less than 18 inches above average grade.
- “Structure, rail dependent” means a structure with a primary function requiring close proximity to railroad tracks.
- “Subdivider” means any person having an ownership interest in the land that is the subject of an application for development.
- “Subdivision” means the division of a tract or parcel of land into two or more lots, sites, or other divisions, or the combining of two or more lots, tracts, or parcels into one lot, tract, or parcel for the purpose, whether immediate or future, of sale or lease for more than ten years, including any resubdivision.
- “Subject site” means the property subject to the interim materials district; conditional use permit; or administrative permit for earth materials extraction activities.
- “Swale” means a low-lying or depressed land area commonly wet or moist, which can function as an intermittent drainageway.
- “Tall structure” means a structure that is over 85 feet above grade. The term includes, but is not limited to, tethered balloons, flag poles, sculpture, buildings, elevators, storage or processing facilities, water tanks,

derricks, cranes, signs, chimneys, area illumination poles, towers, broadcast facilities, and supports for communication.

- “Telecommunication facility” means any unmanned facility established for the purpose of providing wireless transmission of voice, data, images, or other information including, but not limited to, cellular telephone service, personal communications service, paging service, and television or radio communications. Telecommunication facilities may include one or more towers, antennas, equipment cabinets, feed lines, ancillary structures, and fencing.
- “Telecommunication tower” means a tower built for the sole or primary purpose of supporting any FCC licensed or authorized antennas and their associated facilities, including structures that are constructed for wireless communications services including, but not limited to, private, broadcast, and public safety services, as well as unlicensed wireless services and fixed wireless services such as microwave backhaul.
- “Topographic features” means the physical land surface relief including terrain elevation and slope.
- “Tower” means a vertical projection composed of metal or other material designed for the purpose of accommodating antennas, wind turbine equipment, or other equipment at a desired height or utilization as a broadcast facility. Examples of tower types include guyed, lattice, monopole, concealed, and other similar type facilities. Towers do not include any device used to attach antennas to an existing building, unless the device extends above the highest point of the building by more than 20 feet.
- “Traditional uses” means an inherited, established, or customary pattern of land uses that may involve a cultural, historical practice, or a social custom.
- “Trail” means a traveled way which may have recreational, aesthetic, alternative transportation, or educational opportunities.
- “Transmission equipment” means equipment that facilitates transmission for any FCC licensed or authorized wireless communication service, including, but not limited to, radio transceivers, antennas, coaxial or fiber-optic cable, and regular backup power supply.
- “Unbuildable” means an area or land that cannot be used practically or is not feasible for a habitable building because of natural conditions, such as a slope exceeding 40 percent, wetlands, floodplains, streams, ponds, or other impeding conditions.
- “Unconfined aquifer” means an aquifer whose upper surface is a water table free to fluctuate.
- “Undeveloped land” means land in its natural state before commencement of construction or placement of any building.

- “Use” means the purpose for which land, a building, or structure is arranged, designated, or intended, is occupied or maintained.
- “Useable open space” means land within or related to a development that is designed and intended for the common use or enjoyment of the residents of the development and may include complementary buildings and improvements as are necessary and appropriate.
- “Variance” means specific grant of relief from one or more of the requirements of this title as provided in MSB 17.65.
- “Water bodies” means permanent or temporary areas of standing or flowing water. Water depth is such that water, and not air, is the principal medium in which organisms live. Water bodies include, but are not limited to: lakes, ponds, streams, rivers, sloughs, and all salt water bodies.
- “Water table” means the upper surface of a zone of saturated soil, including natural seasonal fluctuations, but excluding fluctuations caused by heavy rains or rapid snowmelt; the water table is indicated by the level at which water stands in a well that is open along its length and penetrates the surficial deposits just deeply enough to encounter standing water in the bottom.
- “Wetlands” means those areas that are inundated and saturated by surface or groundwater at a frequency and duration sufficient to support, and that under normal circumstances do support, a prevalence of vegetation typically adapted for life in saturated soil conditions, including swamps, marshes, bogs, and similar areas.
- “Width of a structure” means the horizontal distance measured from the outermost points of the structure including attachments and structural supports but excluding guy wires and transmission lines strung between towers as in the case of electrical power lines.
- “Wind energy conversion system (WECS)” means any device such as a wind charger, windmill, turbine, energy ball, wind tower, or another similar device, which is typically mounted to a tower or pole, and its associated mechanical and electrical equipment, which is designed to convert wind energy to a form of usable energy.
- “Yard” means an open space that lies between the principal building or buildings and the nearest lot line.
- “Yard, front” means a space extending across the full width of the lot between the principal building and the front lot line and measured perpendicular to the building to the closest point of the front lot line.
- “Yard, rear” means a space extending across the full width of the lot between the principal building and the rear lot line and measured perpendicular to the building to the closest point of the rear lot line.
- “Yard, required” means the minimum open space between a lot line and the yard line within which no building

is permitted to be located except as provided by the design standards.

- “Yard, side” means a space extending from the front yard to the rear yard between the principal building and the side lot line and measured perpendicular from the side lot line to the closest point of the principal building.

(Ord. 18-030, § 8, 2018; Ord. 18-013, § 6, 2018; Ord. 17-096, § 5, 2017; Ord. 15-016, § 3, 2015; Ord. 12-169, § 4, 2013; Ord. 12-064, § 3, 2012; Ord. 11-159, § 3, 2011; Ord. 11-153, § 18, 2011; Ord. 11-146, § 8, 2011; Ord. 11-074, § 5, 2011; Ord. 11-019, § 3, 2011; Ord. 09-014, § 3, 2009; Ord. 08-161(AM), § 3, 2008; Ord. 08-136, § 3, 2008; Ord. 08-018(SUB), § 18, 2008; Ord. 08-017(AM), § 3, 2008; Ord. 07-058, § 12, 2007; Ord. 06-192(AM), § 3, 2007; Ord. 06-188(SUB), § 3, 2007; Ord. 05-182(AM), § 9, 2005; Ord. 05-125(SUB)(AM), § 2 (part), 2005)



# 2022 SUBDIVISION CONSTRUCTION MANUAL

Matanuska-Susitna Borough  
Public Works Department

(Roads, Drainage, and Utilities)  
Adopted Date: July 19, 2022  
Effective Date: July 19, 2022

IM 26-045  
OR 26-031

CODE ORDINANCE

Sponsored by: Borough Manager  
Introduced: 06/21/22  
Public Hearing: 07/19/22  
Adopted: 07/19/22

**MATANUSKA-SUSITNA BOROUGH  
ORDINANCE SERIAL NO. 22-057**

AN ORDINANCE OF THE MATANUSKA-SUSITNA BOROUGH ASSEMBLY AMENDING MSB 43.05.015 PURPOSE AND SCOPE, TO REFERENCE THE 2022 SUBDIVISION CONSTRUCTION MANUAL UPDATE.

---

BE IT ENACTED:

Section 1. Classification. This ordinance is of a general and permanent nature and shall become a part of the Borough Code.

Section 2. Amendment of section. MSB 43.05.015(B)(3) is hereby amended to read as follows:

(3) [2020] **2022** Subdivision Construction Manual.

Section 3. Effective date. This ordinance shall take effect upon adoption.

ADOPTED by the Matanuska-Susitna Borough Assembly this 19 day of July, 2022.

  
EDNA DeVRIES, Borough Mayor

ATTEST:

  
LONNIE R. McKECHNIE, CMC, Borough Clerk

(SEAL)

PASSED UNANIMOUSLY: Hale, Nowers, McKee, Yundt, Tew, Sumner, and Bernier

# Table of Contents

Acronyms .....	iv
Definitions .....	v
Introduction .....	1
Section A. Street Design.....	2
<b>A01</b> General.....	2
<b>A02</b> Applicability.....	2
<b>A03</b> Street Classifications.....	2
<b>A04</b> Access Criteria.....	4
<b>A05</b> Design Criteria.....	6
<b>A06</b> Typical Section .....	9
<b>A07</b> Turnarounds.....	9
<b>A08</b> Stub Streets.....	11
<b>A09</b> Intersections .....	11
<b>A10</b> Driveways.....	14
<b>A11</b> Trailhead .....	14
<b>A12</b> Bicycle and Pedestrian Paths .....	14
<b>A13</b> Signage .....	14
<b>A14</b> Railroad Crossings.....	17
<b>A15</b> Average Daily Traffic.....	17
<b>A16</b> Design Deviations.....	17
Section B. Major Road Corridors .....	18
<b>B01</b> General.....	18
<b>B02</b> Right-of-way and Surface Widths .....	18
<b>B03</b> Frontage, Backage, and Connector Street Standards.....	18
<b>B04</b> Access Standards.....	19
<b>B05</b> Future Corridors.....	20
<b>B06</b> References .....	20
Section C. Construction Requirements.....	21
<b>C01</b> General.....	21
<b>C02</b> Road Construction .....	21
<b>C03</b> Roads Outside of a Road Service Area .....	23
<b>C04</b> Pioneer Road Construction Requirements .....	23
<b>C05</b> Winter Construction .....	23
<b>C06</b> Alternate Methods and Materials.....	23
<b>C07</b> Materials .....	23
Section D. Drainage.....	26
<b>D01</b> General.....	26
<b>D02</b> Requirements.....	26

<b>D03</b>	Drainage Design Criteria .....	27
<b>D04</b>	Drainage Ditches .....	29
<b>D05</b>	Culverts .....	30
<b>D06</b>	Fish Passage Culverts .....	31
<b>D07</b>	Soil Infiltration Facilities.....	34
<b>D08</b>	Rainfall Data.....	34
Section E.	Easements.....	35
<b>E01</b>	General.....	35
Section F.	Development Implementation .....	37
<b>F01</b>	General.....	37
Section G.	Commercial and Industrial Subdivisions.....	41
<b>G01</b>	General.....	41
Section H.	Utilities .....	42
<b>H01</b>	General.....	42
<b>H02</b>	Utility Location Guidelines.....	42
References	.....	44
Appendix A	.....	45

## Figures

Figure A-1: Loop Residential Streets.....	4
Figure A-2: Loop Residential Subcollector Streets.....	5
Figure A-3: Typical Section.....	9
Figure A-4: Cul-de-sac Options .....	10
Figure A-5: Alternate Turnarounds.....	10
Figure A-6: Intersection Sight Distance.....	12
Figure A-7: Intersection Offset .....	13
Figure A-8: Intersection Angle .....	13
Figure A-9: Controlled Street Landing Profile.....	14
Figure A-10: Sign Placement .....	15
Figure A-11: Stop Sign Location .....	16
Figure A-12: Concrete Foundation for Sign Post .....	16
Figure B-1: Frontage Street Configurations .....	19
Figure C-1: Structural Sections for Gravel Roads.....	24
Figure C-2: Structural Sections for Paved Roads .....	25

## Tables

Table A-1: Design Criteria .....	7
Table A-2: Recommended and Minimum Intersection Sight Distance .....	12
Table B-1: ROW and Surface Widths .....	18
Table B-2: Average Access Point Spacing.....	20
Table C-1: Aggregate Quality Properties for Base Course .....	24
Table C-2: Aggregate Gradations.....	24
Table D-1: Drainage Sizing and Analysis Criteria .....	28
Table D-2: Ditch Stabilization.....	29
Table D-3: Ditch Lining Materials.....	30

## Section A. Acronyms & Abbreviations

AASHTO	American Association of State Highway and Transportation Officials
ADFG	Alaska Department of Fish and Game
ADT	Average Daily Traffic
ADOT&PF	Alaska Department of Transportation and Public Facilities
ATM	Alaska Test Method
cfs	cubic feet per second
DPW	Department of Public Works of the Matanuska-Susitna Borough
FHWA	Federal Highway Administration
ft	feet
h:v	Horizontal to vertical
IDF	Intensity-Duration-Frequency
IFC	International Fire Code
in	inches
ITE	Institute of Transportation Engineers
LEW	Low Erosivity Waiver
LRTP	Long Range Transportation Plan
mph	miles per hour
MSB	Matanuska-Susitna Borough
N/A	Not applicable
NOAA	National Oceanic and Atmospheric Administration
NRCS	Natural Resources Conservation Service
NTP	Notice to proceed
OHWM	Ordinary high water mark
OSHP	Official Streets and Highways Plan
PUE	Public use easement
ROW	Right-of-way
SCS	Soil Conservation Service
VPD	Vehicles per day

## Section B. Definitions

<b>Access Point</b>	The location along a road at which a driveway or road intersects.
<b>Arterial</b>	A road that provides a high level of mobility within the transportation network. Arterials have managed access with a minimal number of intersections or interchanges.
<b>Average Daily Traffic</b>	The total number of vehicle trips during a given time period (in whole days greater than one day and less than one year) divided by the number of days in that time period.
<b>Backslope</b>	On a roadway section in a cut, the portion of the roadside that slopes up from the roadside ditch and away from the roadway to the top of the cut, see Figure A-3.
<b>Catchment Area</b>	The total area contributing stormwater runoff to a particular point, site, or structure.
<b>Collector</b>	A road that links local roads with arterials and performs some duties of each. Collectors have managed access with a moderate number of intersections and driveways.
<b>Curve Return</b>	The curve located at the corner of an intersection, connecting the roadway edge of one road to the roadway edge of an intersecting road or driveway.
<b>Detention</b>	The temporary storage of runoff, for later controlled release.
<b>Drainage Pattern</b>	The configuration of a drainage system including manmade and natural features within a catchment area.
<b>Driveway</b>	A vehicular access way between a road and a parking area within a lot or property.
<b>Embankment</b>	Earthen material that is placed and compacted for the purpose of raising the grade of a roadway.
<b>Engineer</b>	An individual who is registered as a Professional Civil Engineer in the State of Alaska.

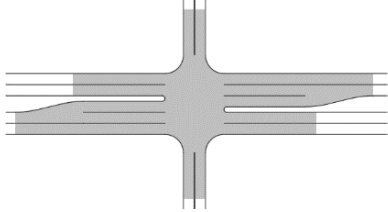
<b>Feasible</b>	Reasonable and capable of being done or carried out.
<b>Foreslope</b>	On a roadway section, the portion of the roadside that slopes down and away from the roadway, see Figure A-3.
<b>Functional Area</b>	<p>The physical area of an intersection and the area extending both upstream and downstream which includes perception reaction distance, maneuver distance, and storage length.</p> 
<b>Intersection</b>	The general area where two or more roads join or cross.
<b>Local Road</b>	A road that provides access to abutting property, rather than to serve through traffic. Local roads are not access controlled and can have frequent intersections and driveways.
<b>Lot Frontage</b>	A property line that abuts the right-of-way that provides access to the lot.
<b>Ordinary High Water Mark</b>	The elevation marking the highest water level which has been maintained for a sufficient time to leave evidence upon the landscape. Generally, it is the point where the natural vegetation changes from predominately aquatic to upland species.
<b>Positive Drainage</b>	Clear, unobstructed flow of water away from structures and roadways without localized ponding.
<b>Public Use Easement</b>	Provides the rights for ingress, egress, roadways, right-of-way, public utilities, and slopes for cuts and fills. The rights are to the public in general, and public utilities governed by permits required under federal, state, and local laws and regulations. May also be known as a public access easement or right-of-way.
<b>Regulated Stream</b>	Any watercourse along which the flood hazard areas have been mapped and approved by the Federal Emergency Management Agency; any stream which harbors fish, as determined by the Alaska Department of Fish and Game; or any stream designated as regulated by MSB.
<b>Retention</b>	The prevention of runoff. Stormwater, which is retained, remains indefinitely, with the exception of the volume lost to evaporation, plant uptake, or infiltration.

<b>Right-of-way</b>	A strip of land reserved, used, or to be used for a street, alley, walkway, airport, railroad, or other public or private purpose.
<b>Road</b>	A general term denoting a public thoroughfare used, or intended to be used, for passage or travel.
<b>Road Prism</b>	The foundation that supports the roadway; see Figure A-3.
<b>Roadway</b>	The portion of a road that includes driving lanes and shoulders, see Figure A-3.
<b>Segment</b>	A portion of road between two significant intersections or an intersection and its terminus.
<b>Shoulder</b>	The portion of a roadway contiguous to any traveled way for lateral support of surface courses, see Figure A-3.
<b>Street</b>	A general term usually denoting an urban or suburban road.
<b>Stub</b>	A right-of-way or road segment that is planned to be extended, typically short in length, which terminates at the boundary of a subdivision or masterplan phase.
<b>T-intersection</b>	A three leg intersection in the form of a “T”.
<b>Through Street</b>	A road given preferential right of way; roads which intersect a through street are controlled, such as with a stop sign or yield sign.
<b>Water Body</b>	A permanent or temporary area of standing or flowing water. Water depth is such that water, and not air, is the principal medium in which organisms live. Water bodies include, but are not limited to: lakes, ponds, streams, rivers, sloughs, and all salt water bodies.

## Introduction

This manual is intended to accomplish the following goals:

- (1) To establish standards for the design and construction of transportation networks throughout the Matanuska-Susitna Borough.
- (2) To provide information and guidelines for the design, construction, and upgrade of roads, drainage facilities, and utilities within rights-of-way.
- (3) To develop and maintain a safer and more efficient transportation system.
- (4) To minimize operation & maintenance efforts.

## Section A. Street Design

### A01 General

These provisions establish appropriate standards for the design of roads. The purpose of these provisions is to:

- (1) promote the safety and convenience of motorized and non-motorized traffic;
- (2) promote the safety of neighborhood residents;
- (3) minimize the long term costs for maintenance and repair;
- (4) protect the residential qualities of neighborhoods by limiting traffic volume, speed, noise, and air pollution;
- (5) encourage the efficient use of land; and
- (6) minimize the cost of road construction and thereby restrain the rise in housing costs.

### A02 Applicability

These standards apply to the design and construction of all subdivision improvements within the Matanuska-Susitna Borough (MSB), with the exception of those streets within cities that exercise road powers by ordinance.

### A03 Street Classifications

Roads within the MSB fall within one of the following functional classifications, in accordance with the Long Range Transportation Plan (LRTP): Interstate, Principal Arterial, Minor Arterial, Major Collector, Minor Collector, and Local Road. Functional classification of a road is based on its function, design, and current potential use. The applicant may request review of the functional classification of existing roads abutting or affecting the design of a subdivision or land development during the preapplication process.

This section provides design guidance for roads falling under local road and minor collector functional classifications.

#### A03.1 Residential Street

Residential streets are local roads intended to carry the least amount of traffic at the lowest speed. The Residential street will provide the safest and most desirable environment for a residential neighborhood. Developments should be designed so that all, or the maximum number possible, of the homes will front on this class of street.

#### A03.2 Residential Subcollector Street

Residential Subcollector streets are local roads that carry more traffic than Residential streets.

### A03.3 Residential Collector Street

Residential Collector streets are the highest order of residential streets and are a type of minor collector. In large residential developments, this class of street may be necessary to carry traffic from one neighborhood to another or from the neighborhood to other areas in the community. Residential Collector streets should provide the fewest direct accesses as possible.

### A03.4 Mountain Access Road

Mountain Access Roads may be used in areas where the average cross slope exceeds 15 percent or to traverse terrain features in excess of 25 percent. Maintenance of Mountain Access Roads will be at the discretion of Department of Public Works (DPW). School bus access should be considered as school bus routes require all grades less than 10 percent. Mountain Access Road standards allow for steeper grades and switchbacks, but should otherwise be designed to Residential, Residential Subcollector, or Residential Collector standard as required by this section.

### A03.5 Pioneer Road

Pioneer Roads may only be used where allowed by MSB or other applicable code. This classification establishes minimum requirements for roads providing physical access, but should otherwise be designed to Residential, Residential Subcollector, or Residential Collector standard as required by this section. No MSB maintenance will be provided for Pioneer Roads. Pioneer roads may be constructed offset from the centerline of the ROW to facilitate future expansion of the road.

### A03.6 Alleys

Alleys are permitted provided legal and physical access conforms to MSB or other applicable code. No MSB maintenance will be provided for Alleys.

### A03.6 Other Street Types

The above classifications may be further typed as one of the following streets. These other street types should be designed to Residential, Residential Subcollector, or Residential Collector standard as required by this section.

- (a) Frontage Street – streets parallel and adjacent to a major road corridor which provides access to abutting properties and separation from through traffic. See Section B for additional design standards.
- (b) Backage Street – streets that provide access to lots located between the Backage Street and a major road corridor. See Section B for additional design standards.
- (c) Connector Street – the portion of a street that connects a frontage or backage street to a major road corridor. See Section B for additional design standards.
- (d) Divided Street – streets may be divided for the purpose of accommodating environmental features or avoiding excessive grading. In such a case, the design standards shall be applied to the appropriate street classification and a single lane width with a shoulder on each side.

## A04 Access Criteria

### A04.1 Residential Street

- (a) A Residential street provides access to abutting properties.
- (b) The anticipated average daily traffic (ADT) volume on Residential streets shall not exceed 400. A loop street shall be designed such that the anticipated ADT at each terminus of the loop street does not exceed 400, see Figure A-1.
- (c) Residential streets may intersect or take access from an equal or higher classification street. Both ends of a loop Residential street are encouraged to intersect the same collecting street and be designed to discourage through traffic.

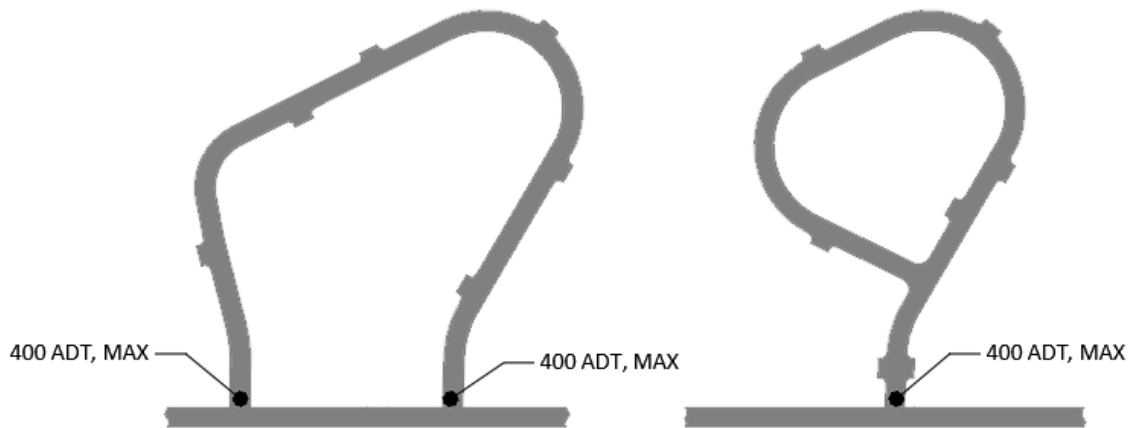

Figure A-1: Loop Residential Streets

### A04.2 Residential Subcollector Street

- (a) A Residential Subcollector street provides access to abutting properties and may also move traffic from Residential streets that intersect it. Residential Subcollector streets are required when the ADT anticipated on the street will exceed the limits for Residential.
- (b) The anticipated ADT on Residential Subcollector streets shall not exceed 1000. A loop street shall be designed such that the anticipated ADT at each terminus of the loop street does not exceed 1000, see Figure A-2.
- (c) Residential Subcollector streets shall be designed to exclude all external through traffic that has neither origin nor destination on the Residential Subcollector or its tributary Residential streets. Adjacent parcels may acquire access if proven landlocked by legal or terrain features or if such Residential Subcollector access can be demonstrated to be beneficial to the public.
- (d) Residential Subcollector streets shall take access from a street of equal or higher classification.
- (e) Traffic calming elements should be considered for the design of Residential Subcollectors, such as avoiding long, straight segments and reducing the length of roadway from farthest lot to a collector.

- (f) Residential Subcollector streets shall be provided with two continuous moving lanes within which no parking is permitted.

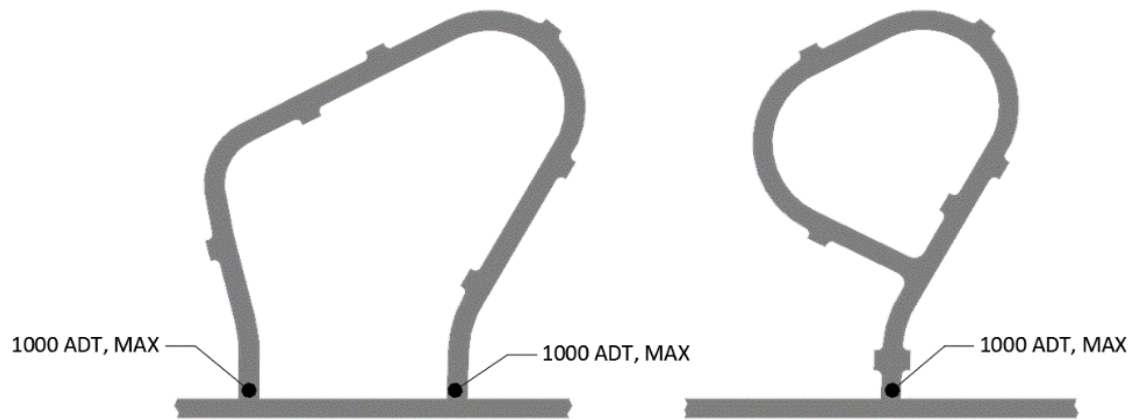

Figure A-2: Loop Residential Subcollector Streets

### Residential Collector Street

- (a) A Residential Collector street carries residential neighborhood traffic, but restricts or limits direct residential access. Residential Collector streets are required when the ADT anticipated on the street will exceed the limits for Residential Subcollectors.
- (b) Residential Collector streets should be designed to have as few residential lots directly fronting them as possible. When efficient subdivision design or physical constraints make this not possible, the average access point spacing shall be a minimum of 250 feet. Average access point spacing is calculated per segment and is equal to the segment length divided by the number of potential access points on both sides of the street. Undeveloped lots with only access to Residential Collector streets are counted as having at least one access point. When the average access point spacing on a segment of an existing Residential Collector street is less than 250 feet, the average access point spacing shall not decrease due to the subdivision.
- (c) Space shall be provided on these lots for turnaround so that vehicles will not have to back out onto Residential Collector streets.
- (d) Proposed access points on Residential Collector streets shall be shown on the preliminary plat.
- (e) Residential Collector streets shall be laid out to encourage connectivity within the transportation network.
- (f) If the anticipated ADT will exceed 3000, the street shall be classified at a higher level than Residential Collector by DPW.
- (g) Every Residential Collector shall be provided with no fewer than two access intersections to streets of equal or higher classification. If it is shown by the applicant that two accesses are not feasible, Residential Collector streets shall be provided with access to one street of equal or higher classification and be designed to accommodate a future second connection to a street of equal or higher classification, or otherwise be approved by DPW.
- (h) All Residential Collector streets shall be provided with two continuous moving lanes within which no parking shall be permitted.

#### A04.4 Access through Existing Streets

The anticipated ADT on existing Residential streets used to access a proposed subdivision may exceed 400, but shall not exceed 800, if:

- (a) alternate road corridors are not available or feasible;
- (b) horizontal geometry or access density prohibits upgrade to a higher standard road; and
- (c) the traffic impacts are mitigated.

#### A04.5 Traffic Impact Mitigation for Access through Existing Streets

Traffic impact mitigation on existing residential streets can include but is not limited to:

- (a) Traffic control devices (signage, striping) on segments where potential ADT exceeds 440;
- (b) LED street lighting, speed feedback signs, widened shoulders, inside corner widening for offtracking, or all-way stop intersections on segments where potential ADT exceeds 600.

#### A04.6 Commercial Uses on Residential and Residential Subcollector Streets

Exceptions to the ADT limits on Residential and Residential Subcollector streets, as set forth in A04.1 and A04.2, respectively, may be allowed for commercial uses that access the first 600 feet of such streets that intersect a Collector standard road or higher classification, as measured from the intersection point. The affected portion of the street and intersection shall be constructed to a higher standard as needed to accommodate the anticipated commercial traffic.

#### A05 Design Criteria

The design criteria for Residential, Residential Subcollector, and Residential Collector streets and Mountain Access and Pioneer roads are set forth in Table A-1. Any unspecified design criteria shall meet or exceed the design criteria for the roadway design speed in the latest edition of *A Policy on Geometric Design of Highways and Streets* (AASHTO).

**Table A-1: Design Criteria**

	Unit	Residential	Residential Subcollector	Residential Collector	Mountain Access <sup>1</sup>	Pioneer <sup>1</sup>
Average Daily Traffic	VPD	≤400	401 – 1000	1001 – 3000	–	–
<b>Typical Section</b>						
ROW Width <sup>2</sup>	ft	60	60	60	60	60
Lane Width	ft	10	10	11	10	10
Standard Gravel Shoulder Width	ft	2	2	2	0 <sup>3</sup>	0 <sup>3</sup>
Shared Paved Shoulder Width <sup>4</sup>	ft	4	4	6	–	–
Roadway Width	ft	24	24	26	20 <sup>3</sup>	20
Foreslope <sup>5</sup>	h:v	3:1	3:1	4:1	2:1	3:1
Backslope <sup>6</sup>	h:v	2:1	2:1	2:1	2:1 <sup>7</sup>	2:1
Crown, gravel	%	3	3	3	3	3
Crown, pavement	%	2	2	2	2	–
<b>Engineering Criteria</b>						
Design Speed	mph	25	30	35	–	–
Posted Speed	mph	20	25	30	–	–
Stopping Sight Distance	ft	155	200	250	–	–
<b>Horizontal Alignment</b>						
Minimum Centerline Radius	ft	225	350	550	– <sup>8</sup>	–
with DPW Approval	ft	190	275	400	–	–
Minimum Tangent Between Curves	ft	100	100	100	100	100
Maximum superelevation	%	N/A	N/A	4	N/A	N/A

<sup>1</sup> Where a value is not given, Mountain Access and Pioneer Roads shall meet the criteria of the anticipated street classification.

<sup>2</sup> Minimum ROW required for new dedications; width of existing ROW may vary.

<sup>3</sup> Where grades exceed 7 percent, the shoulder width shall be 2 feet for a total roadway width of 24 feet.

<sup>4</sup> An optional paved shoulder may be provided on one or both sides of paved streets for non-motorized shared use.

<sup>5</sup> Slope for the first 7.5 feet from the shoulder; may be steepened to 2:1 thereafter. Install guardrail when required by the latest edition of the *Roadside Design Guide* (AASHTO).

<sup>6</sup> 2:1 Back slopes may be steepened to 1.5:1 if cuts exceed 5 feet and appropriate slope stabilization, as determined by the design engineer, is used. Retaining walls may be used to replace or augment backslopes.

<sup>7</sup> Or backslope recommended by the design engineer based on actual conditions.

<sup>8</sup> Switch backs are allowed provided cul-de-sac criteria is met or turning radius is 40 feet with a 2% grade.

	Unit	Residential	Residential Subcollector	Residential Collector	Mountain Access <sup>1</sup>	Pioneer <sup>1</sup>
<b>Vertical Alignment</b>						
Maximum Centerline Grade	%	10	10	10	15 <sup>9</sup>	10
Minimum Rate of Vertical Curvature <sup>10</sup> ; Crest		12	19	29	–	–
Minimum Rate of Vertical Curvature <sup>10</sup> ; Sag		26	37	49	–	–
Minimum Flow Line Grades	%	0.5	0.5	0.5	1.0	0.5
<b>Intersections</b>						
Minimum ROW Corner Radius	ft	30	30	30	30	30
Minimum Curve Return Radius <sup>11</sup>	ft	20	25	30	–	–
Maximum Grade on through street within 50 feet of intersection	%	7	7	4	9	7

<sup>9</sup> Up to 15% grade with no more than 200 linear feet of over 10% grade with a minimum of 100 linear feet of less than 10% grade for runout between steeper sections. Maximum grade in a horizontal curve is 10%.

<sup>10</sup> Rate of vertical curvature (K) is the length of curve (L) in feet per percent algebraic difference in intersecting grades (A);  $K = L / A$

<sup>11</sup> 40-foot minimum curve return radius at intersections with higher order streets.

## Typical Section

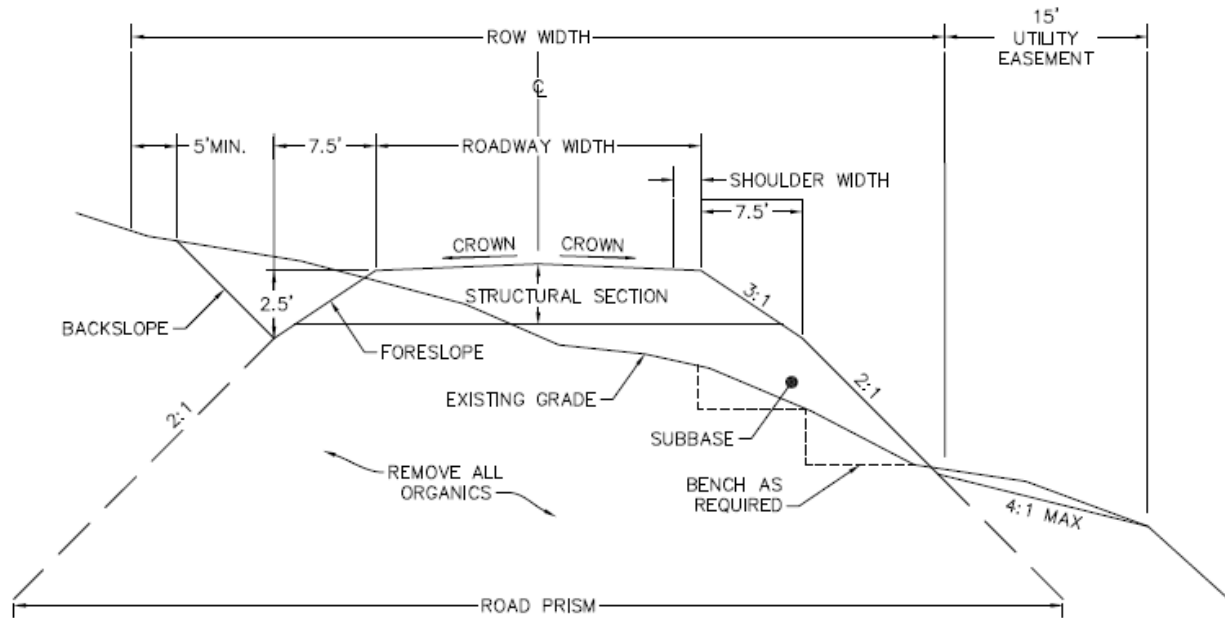

**Figure A-3: Typical Section**

## A07 Turnarounds

Streets with only one inlet shall terminate with a constructed turnaround, unless otherwise provided by A08.2.

### A07.1 Cul-de-sac Turnarounds

- (a) A cul-de-sac turnaround with a drivable surface diameter (shoulder to shoulder) of 85 feet centered in a ROW diameter of 120 feet shall be provided at the terminus of Residential and Residential Subcollector streets.
- (b) Cul-de-sac turnarounds shall meet the configuration and dimensions shown in Figure A-4.
- (c) The grade throughout the surface of a cul-de-sac, as depicted in the shaded portion of Figure A-4, shall not exceed 4 percent.

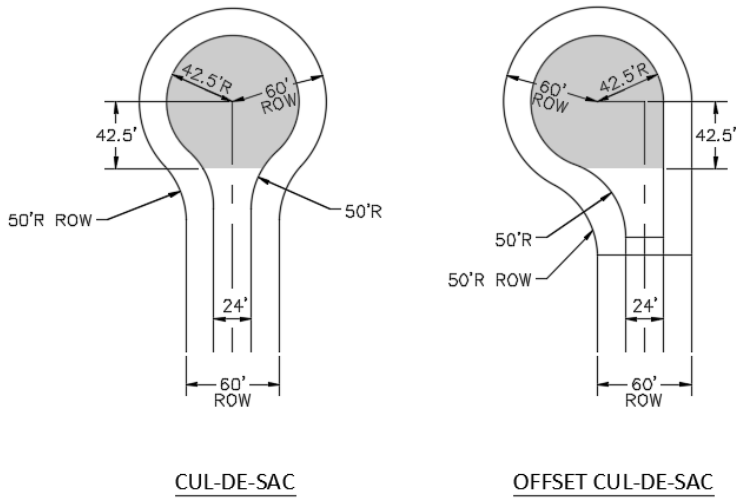

Figure A-4: Cul-de-sac Options

A07.2 Alternate Turnarounds

- (a) DPW may permit a street to terminate with an alternative turnaround that meets fire code when such a design is required by extreme environmental or topographical conditions, unusual or irregularly shaped tract boundaries, or when the location of the turnaround is intended to become an intersection.
- (b) Alternate turnarounds shall meet the configuration and dimensions shown in Figure A-5.
- (c) The grade throughout the turnaround surface, as depicted in the shaded portion of Figure A-5, shall not exceed 4 percent.

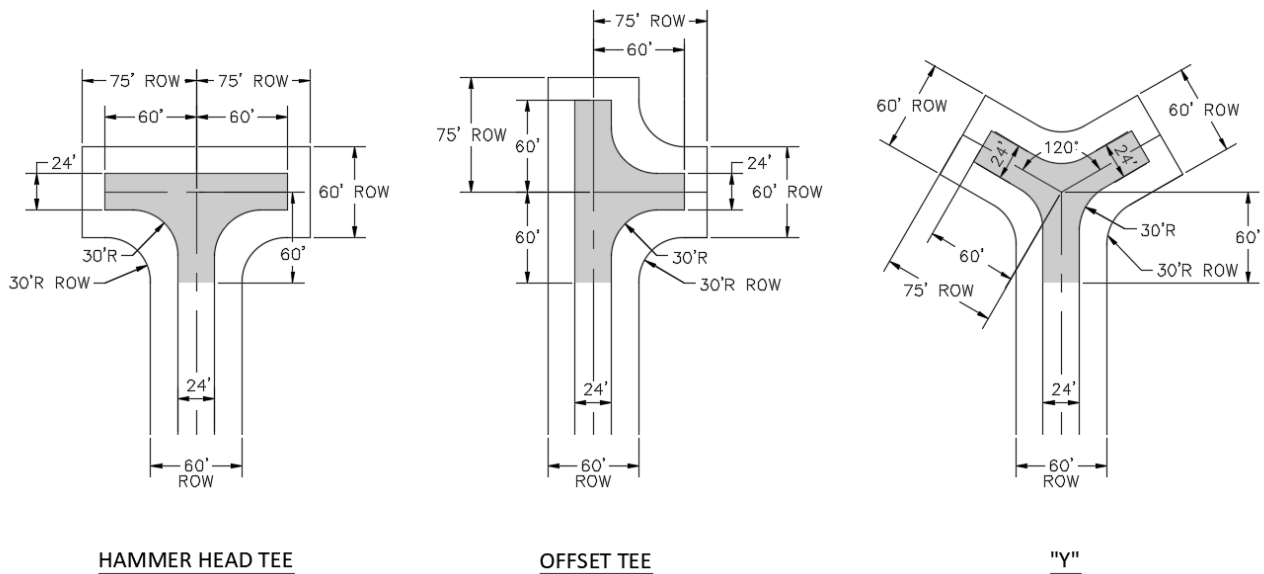

Figure A-5: Alternate Turnarounds

## A08 Stub Streets

### A08.1 Stub Street Construction

No construction is required if physical access is provided to all lots by adjoining streets as required by MSB or other applicable code.

### A08.2 Temporary Turnarounds

Stub streets requiring construction that exceed 200 feet in length (measured from the intersection point to the end of required construction) will meet the requirements of A07.1 or A07.2. A temporary easement will be provided for the turnaround, which will automatically terminate upon extension of the street and physical removal of the turnaround. The centerline grade on stub streets without turnarounds shall not exceed 4%.

## A09 Intersections

### A09.1 Intersection Sight Distance

- (a) Whenever a proposed street intersects an existing or proposed street of higher order, the street of lower order shall be made a stop controlled street, unless alternate intersection control is used as allowed by this subsection.
- (b) Stop controlled streets shall be designed to provide intersection sight distance as specified in this subsection, Table A-2, and Figure A-6.
- (c) The entire area of the intersection sight triangles shown in Figure A-6 shall be designed to provide a clear view from point A at 3.5 feet above the roadway to all points 3.5 feet above the roadway along the lane centerlines from point B to point C and point D to point E.
- (d) Sight distances less than the recommended shall only be used when there are topographical or other physical constraints outside of the applicant's control.
- (e) The minimum sight distances listed in Table A-2 are for a passenger car to turn onto a two-lane undivided street and minor road approach grades of 3 percent or less. For other conditions, the minimum sight distance should be calculated by the applicant's engineer according to *A Policy on Geometric Design of Highways and Streets* (AASHTO).
- (f) Sight distances less than the minimum, where no other options exist, will require alternate intersection control or warning signs as determined by the applicant's engineer and approved by DPW.
- (g) Intersection sight triangles shall be located in their entirety within ROW or a sight distance maintenance easement.
- (h) Yield controlled intersections shall conform to sight distance requirements according to *A Policy on Geometric Design of Highways and Streets* (AASHTO).
- (i) Intersections with state or other municipal ROW are subject to their respective requirements and review.

Table A-2: Recommended and Minimum Intersection Sight Distance

Design Speed or Posted Speed Limit (whichever is greater)	S <sub>d</sub> Recommended	S <sub>d</sub> Minimum
MPH	ft	ft
25	370	280
30	450	335
35	580	390
40	750	445
45	950	500
50	1180	555
55	1450	610
60	1750	665
65	2100	720

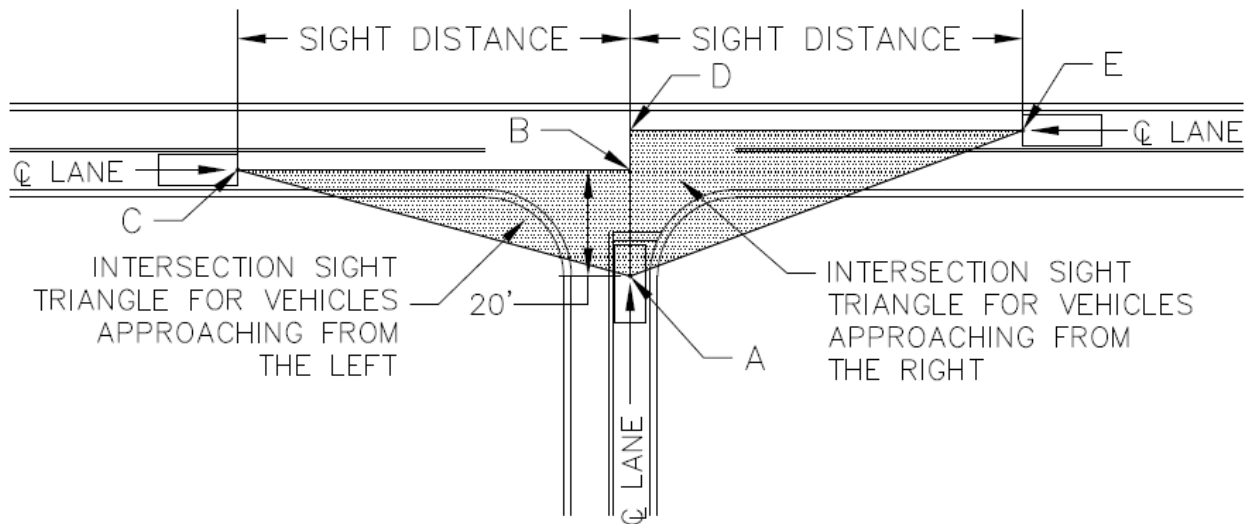
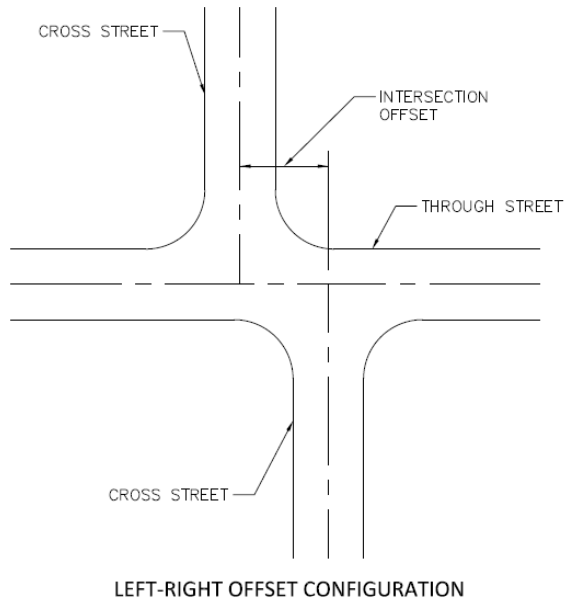

Figure A-6: Intersection Sight Distance

### A09.2 Intersection Spacing

- (a) Minimum centerline to centerline distance between intersections on the same side or opposing sides of the through street shall be:
  - (1) 155 feet on Residential streets;
  - (2) 200 feet on Residential Subcollector streets;
  - (3) 300 feet on Residential Collectors and Minor Collectors; or
  - (4) 650 feet on higher order streets where other access standards do not exist.
- (b) If the above spacing along the through street cannot be met, intersections shall be aligned directly across from each other. Intersections on opposing sides of the through street may be offset up to 30 feet, with a preference for a left-right offset, as shown in Figure A-7.

- (c) Where pre-existing conditions do not allow for the above spacing and no other legal access exists, alternate spacing or offset most closely meeting (a) or (b) above may be allowed.
- (d) Additional intersections should be avoided within the functional area of major intersections with turning bays and approach tapers. Exceptions require DPW approval based upon constraints and no other feasible alternatives.



**Figure A-7: Intersection Offset**

### A09.3 Minimum Intersection Angle

Streets should intersect with a straight segment at an angle as close to 90° as possible, but no less than 70°, for a minimum of 75 feet from the intersection point, as shown in Figure A-8.

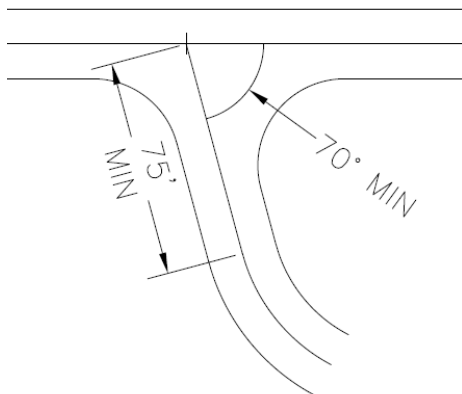

**Figure A-8: Intersection Angle**

#### A09.4 Landing

Controlled streets shall be provided with a typical 30-foot landing, conforming to Figure A-9, at its approach to a through street. The landing shall be sloped to match the crown of the through street. Vertical curves shall not be located in the landing to the extent feasible. Where a negative slope away from the through street is not feasible due to topographical constraints, the road shall be constructed in a manner that prevents water from flowing onto the through street.

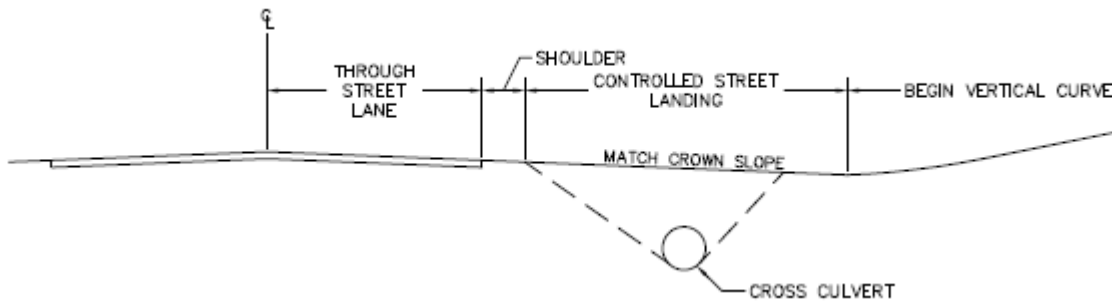

Figure A-9: Controlled Street Landing Profile

#### A09.5 Paved Apron

A proposed street which intersects an existing paved street shall be provided with a paved apron 40 feet from the edge of the existing pavement.

#### A10 Driveways

Driveways are not usually required to be constructed within the ROW at time of road construction. However, if an applicant chooses to construct driveways, driveway permits are required. The applicant may permit all driveways with one application. A driveway permit application can be obtained from the MSB Permit Center. Driveways onto state or other municipal ROW are subject to their respective requirements and review.

#### A11 Trailhead

Trailhead parking lot layout shall conform to applicable local, state, and federal requirements.

#### A12 Bicycle and Pedestrian Paths

Bicycle and pedestrian paths constructed within public ROW shall conform to the current edition of *Guide for the Development of Bicycle Facilities* (AASHTO), and any other applicable local, state, and federal requirements.

#### A13 Signage

Signs shall be provided and installed by the applicant in conformance with the latest edition of the *Alaska Traffic Manual* (ADOT&PF) and the *Alaska Sign Design Specifications* (ADOT&PF) prior to plat recordation.

- (a) Each street within a subdivision shall be identified and signed at its point of egress and ingress. Cul-de-sac streets will be signed and identified at their point of ingress
- (b) Intersection control signs shall be provided at designated intersections within the confines of the subdivision and at the intersection with the access road, if applicable.
- (c) Intersection control signs shall be located such that they are visible to approaching traffic and near corresponding stop or yield bars.
- (d) Speed limit signs shall be provided at entrances to the subdivision, where the speed limit changes, and at a minimum of one-mile intervals throughout the subdivision.
- (e) If a constructed stub street provides access to two or fewer lots and has no turnarounds a sign indicating a dead-end street shall be posted.
- (f) If a dedicated stub street is not constructed, no signs are required.
- (g) Install signs according to the criteria in Figure A-10, Figure A-11, and Figure A-12.
- (h) Signs within state or other municipal ROW are subject to their respective requirements and review.

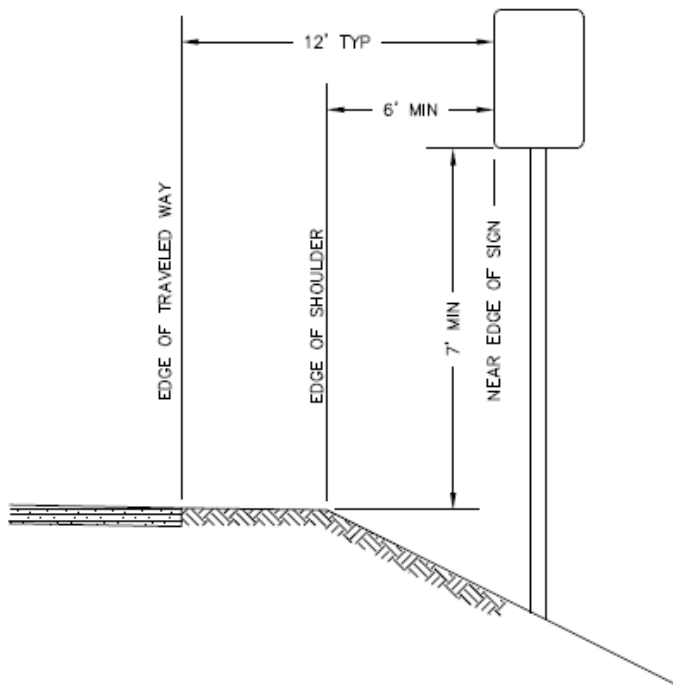

**Figure A-10: Sign Placement**

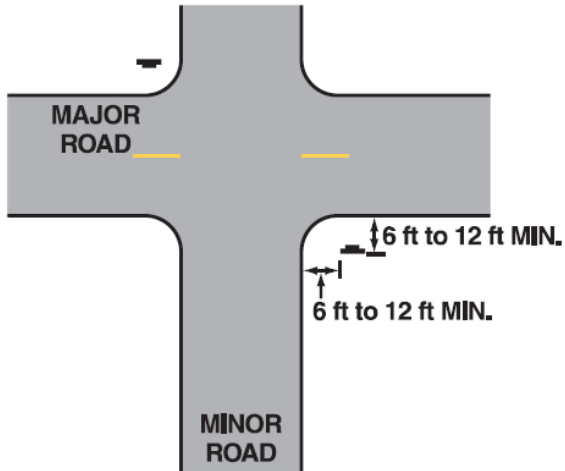
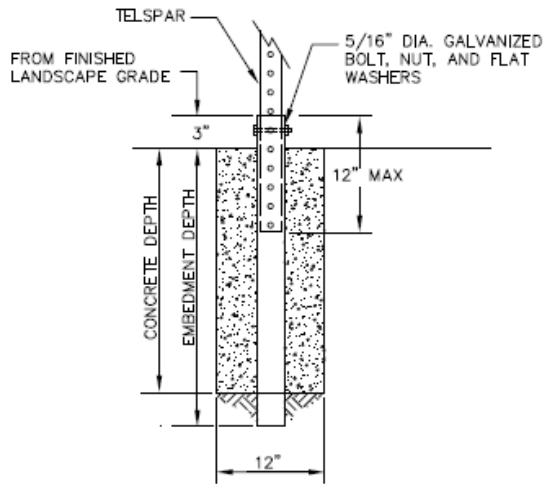

Figure A-11: Stop Sign Location



PERFORATED STEEL TUBES (P.S.T.) (12ga. - .105" Wall Thickness)			
SIGN SURFACE AREA SQ. FT.	POST SIZE	EMBEDMENT DEPTH	CONCRETE DEPTH
7' OR LESS	2" X 2"	27"	24"
GREATER THAN 7'	2 1/2" X 2 1/2"	33"	30"

Figure A-12: Concrete Foundation for Sign Post

#### A14 Railroad Crossings

All access requiring a crossing of the Alaska Railroad shall be subject to the *Alaska Policy on Railroad/Highway Crossings* (Alaska Railroad).

#### A15 Average Daily Traffic

- (a) The following formula shall be used to determine the required classification of streets:  
ADT = Number of lots x 10 for single-family residential use.
- (b) See Section G for other land uses.
- (c) For subdivisions of five or more lots, submit potential ADT calculations for the following locations with the preliminary plat:
  - (1) at each intersection within the subdivision,
  - (2) at each intersection en route to an existing Residential Collector street or higher classification, and
  - (3) at an existing Residential Collector street or higher classification.

#### A16 Design Deviations

Design deviations will be considered to address extenuating circumstances including but not limited to: existing substandard ROW, environmental conditions, or existing utilities or other structures. Design deviation requests shall be in writing and contain supporting information, justification, and suggested solutions. Design deviations may be allowed by DPW only for matters that do not fall under the jurisdiction of a Board or Commission. In no circumstances will a roadway width less than 20 feet or foreslopes steeper than 2:1 be allowed. Residential Collector streets shall be no less than 24 feet wide.

## Section C. Major Road Corridors

### B01 General

Major road corridors include major collectors, arterials, and interstates. This section provides references to and guidelines for the design and construction of major road corridors within the MSB.

### B02 Right-of-way and Surface Widths

**Table B-1: Right-of-way and Surface Widths**

Classification	Minimum ROW Width (ft)	Standard Lane Width (ft)	Number of Lanes	Shoulder Width (ft)
Major Collector	80	12	2 – 3	4
Arterial	100	12	3 – 4	4 – 8
Interstate	200	12	4 – 6	12

### B03 Frontage, Backage, and Connector Street Standards

Subdivisions adjacent to planned or existing major road corridors shall plan for future frontage or backage streets when any of the following conditions apply, unless it is shown by the applicant to be not necessary or feasible for future development and public safety with no written objection from the road authority.

- (a) Subdivisions accessing roads that are classified by ADOT&PF as Interstates.
- (b) Subdivisions accessing roads that are or are projected to grow above 20,000 vehicles per day (VPD).
- (c) Subdivisions accessing roads that are or are projected to have four or more lanes or median control per the LRTP or OSHP.
- (d) Subdivisions that require a second access route.
- (e) To gain access to an existing or planned signal.
- (f) Where access to a minor arterial or collector as a connector road is feasible.
- (g) When there are existing or platted frontage or backage routes adjacent to the property.

#### B03.1 Separation Distances

Minimum ROW to ROW separation distance between major corridors and frontage or backage streets shall be:

- (a) 0 feet for locations with no connector street to the major road corridor;
- (b) 100 feet for locations with a connector street to the major road corridor that lie between section lines and planned or existing intersections with other major road corridors;
- (c) 300 feet for locations where the connector street to the major road corridor is on a section line or planned or existing major road corridor.

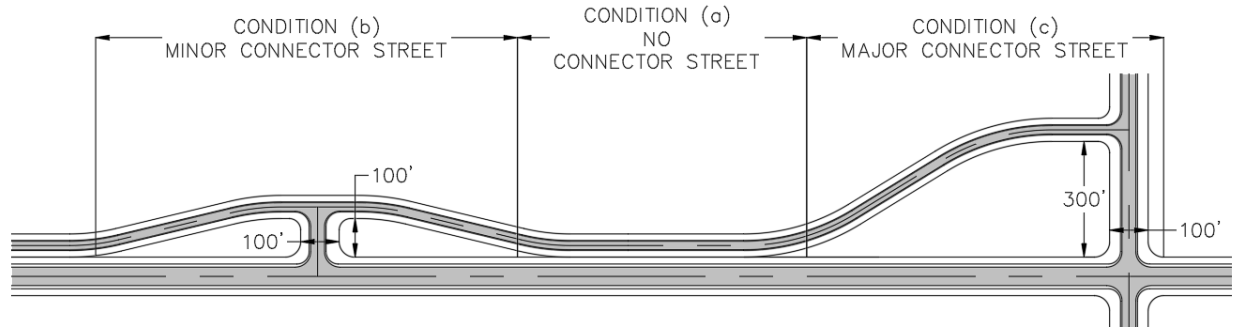

**Figure B-1: Frontage Street Configurations**

## B03.2 Design Standards

- (a) Frontage streets
  - (1) Minimum centerline radii may be reduced near intersections with through connector streets.
- (b) Connector streets
  - (1) 100-foot ROW width desirable.
  - (2) Minimum 40-foot radius curve returns at the major road corridor.
  - (3) Minimum 4-foot wide shoulders for 100 feet from the edge of roadway of the major road corridor.
  - (4) Minimal direct access.

## B03.3 Dedication and Setbacks

Dedicate ROW or additional building setbacks to allow for the frontage, backage, and connector street standards in this manual. The applicant shall submit design information sufficient to demonstrate that frontage, backage, and connector street dedications or building setbacks are in a practical location where road construction is feasible in accordance with this manual. The applicant shall be required to submit plan, profile, and cross-sections for the sections of road where existing grades along the proposed route exceed 10 percent, existing cross slopes exceed 15 percent, or if existing utilities or other physical features appear to create impediments to a road design meeting standards of this manual. Road plan and profile shall extend at least 300 linear feet on either side of the subject sections or to intersecting or adjacent rights-of-way within 500 linear feet.

## B04 Access Standards

- (a) The average access point spacing on major road corridors, where other access standards do not exist, shall not exceed the minimums listed in Table B-2, based on the posted speed limit. Average access point spacing is calculated per segment and is equal to the segment length divided by the number of access points on both sides of the street. Undeveloped lots with only access to the major road corridor are counted as having at least one access point.

- (b) When the average access point spacing on a segment of an existing major road corridor is less than the minimum listed in Table B-2, the average access point spacing shall not decrease due to the subdivision.

**Table B-2: Average Access Point Spacing**

Posted Speed Limit (mph)	Minimum Average Access Point Spacing (feet)
30	250
35	300
40	360
45	425
50	495
55	570

### B05 Future Corridors

Subdivisions shall be designed in a manner that does not conflict with the LRTP or the OSHP. Subdivisions containing future road corridors identified in the LRTP or OSHP are encouraged to include the future road corridor as part of the road layout of the subdivision.

Building setbacks prohibiting the location of any permanent structure within the future corridor may be voluntarily designated on the final plat. The area within the future road corridor shall be excluded from usable septic area calculations. The area within the future road corridor and building setbacks shall be excluded from usable building calculations.

### B06 References

The following publications shall be used for design and construction standards of these classes of streets that are not otherwise established herein:

- (a) *A Policy on Geometric Design of Highways and Streets*, AASHTO (current edition).
- (b) *Standard Specifications for Highway Construction*, ADOT&PF (current edition);
- (c) *Standard Modifications to the ADOT&PF Standard Specifications for Highway Construction*, MSB (latest revision)
- (d) *Alaska Highway Preconstruction Manual*, ADOT&PF (latest revision)

## Section D. Construction Requirements

### C01 General

This section establishes minimum construction requirements. Prior to any ground disturbing activities, call the Alaska Dig Line for utility locates in accordance with AS 42.30.400.

### C02 Road Construction

#### C02.1 Clearing

Cut and dispose of all trees, down timber, stumps, brush, bushes, and debris. Cut trees and brush to a height of not more than 6 inches above the surrounding ground. Clear the ROW, slope easements, and sight distance triangles. Where ROW exceeds 60 feet, clear a minimum of 60 feet. Clear utility easements, if used, for utilities constructed with the development.

#### C02.2 Grubbing

Remove and dispose of all stumps, roots, moss, grass, turf, debris, or other deleterious material within the fill and cut catch limits of the road plus 5 feet on each side, within the ROW, and cleared utility easements for underground utilities.

#### C02.3 Disposal

Dispose of clearing and grubbing debris in an area designated by the applicant outside of all ROW, platted utility easements, and platted private road corridors. Organic debris 3 inches in diameter by 8 inches long, or smaller, may be left in place, outside of the road prism.

#### C02.4 Slit Trenches

Slit trenches are not allowed in the ROW. Utility easements may be used as a borrow source above a 2:1 extension of the road prism, as shown in Figure A-3. Topsoil or other organic non-deleterious material may be disposed within the utility easement. Compact the disposal area with heavy equipment and grade the surface with positive drainage no steeper than 4:1 and no lower than the ditch line. Submit an as-built drawing showing the horizontal locations of borrow extraction along the road corridor with the Final Report.

#### C02.5 Embankment Construction

- (a) Construct the road with the required structural section, see Figure C-1, and dimensions, see Table A-1 and Figure A-3, as determined by its classification.
- (b) Prepare the subgrade. Remove all organics from the area below the road prism and dispose in locations where embankment is not proposed. Bench existing slopes that are steeper than 4:1, measured at a right angle to the roadway, where roadway embankment is to be placed.
- (c) Place material meeting, or verify in-situ material meets, the requirements for Subbase specified in subsection C07 to a minimum depth of 20 inches with the upper 6 inches having no material with

a diameter larger than 6 inches. Place embankment in horizontal layers, as directed by the engineer, for the full width of the embankment and compact as specified before the next lift is placed.

- (d) Place 4 inches of Surface Course meeting the requirements specified in subsection C07. Finish with a 3 percent crown, and compact as specified.
- (e) For Residential and Residential Subcollector standard roads, compact all embankment to not less than 90 percent of the maximum dry density at the optimum moisture content and the top 24 inches to not less than 95 percent of the maximum dry density at the optimum moisture content. For Residential Collector standard roads, compact all embankment to not less than 95 percent of the maximum dry density at the optimum moisture content.
- (f) Optimum moisture and maximum dry density will be determined by Alaska Test Method (ATM) 207 and ATM 212 or alternative methods approved by DPW.
- (g) In-place density shall be determined by ATM 213 or alternative method approved by DPW. Compaction tests on the Subbase layer shall be taken at representative locations along the roadways as follows:
  - (1) a minimum of three;
  - (2) at least one per segment;
  - (3) one additional test per 1000 linear feet, or portion thereof, when the combined length of roadway exceeds 1000 linear feet;
  - (4) at least one out of every three within three feet of the shoulder, and the remainder in the center of a driving lane.
- (h) For paved roadways, substitute Surface Course with a minimum of 2 inches of Base Course and 2 inches of HMA Type II, Class B, for Residential and Residential Subcollector streets, and a minimum of 3 inches of Base Course and 3 inches of HMA Type II, Class B, for Residential Collector Streets. Pavement shall meet MSB Special Provision Section 401 Hot Mix Asphalt Pavement. The width of the pavement shall be equal to two lane widths plus the shared paved shoulder width, if used, and finished with a 2 percent crown. Pavement edges shall be backed with additional Base Course graded and compacted flush with the pavement surface and tapered to the edge of the roadway. The pavement shall be washed or swept immediately following shouldering work.
- (i) Remove all loose material exceeding 6 inches in diameter from the ditches and foreslopes. Where slopes are 3:1 or steeper and longer than 10 feet measured along the slope face, trackwalk perpendicular to the slope, or the equivalent, to form 1-inch wide grooves parallel to the road no more than 12 inches apart.
- (j) Permanently stabilize backslopes 3:1 or steeper. Stabilization can be part of a subdivision agreement. Stabilization may be allowed to establish during the warranty period.

#### C02.6 Unsuitable Subgrades

When structurally unsuitable material such as peat, saturated material, or permafrost are present within the ROW, provide an appropriate structural design for approval by DPW, according to Section F, prior to construction. Place embankment to a depth that will produce a stable road surface with a final grade 18 inches above the surrounding ground.

### C03 Roads Outside of a Road Service Area

Roads outside of a Road Service Area are not subject to the requirement for Surface Course.

### C04 Pioneer Road Construction Requirements

Pioneer roads, whether proposed or existing, shall meet the requirements of Figure C-1, Table A-1, and Figure A-3. Place material meeting, or verify in-situ material meets, the requirements for Subbase specified in subsection C07 to a minimum depth of 12 inches. Additional road embankment may be required to provide a stable road surface. Surface Course is not required. Pioneer roads may be constructed offset from the centerline of the ROW to facilitate future expansion of the road. Cross drainage culverts, minimum 18 inch diameter, will be installed where determined necessary and 24 inch ditches will be provided for drainage.

### C05 Winter Construction

Winter construction may be allowed. DPW will not accept any roads until all ground has thawed and any settlement areas corrected.

### C06 Alternate Methods and Materials

Use of alternate materials and road construction methods that will more appropriately fit the conditions of the specific road locations, following general engineering practices, may be proposed by the applicant or their engineer in writing. Final acceptance of such plans must be approved by DPW.

### C07 Materials

#### C07.1 Subbase

- (a) Is aggregate containing no muck, frozen material, roots, sod, or other deleterious matter;
- (b) has a plasticity index not greater than 6 as tested by (ATM) 204 and ATM 205; and
- (c) meets the requirements of Table C-2, as determined by ATM 304.

#### C07.2 Base Course

- (a) Crushed stone or crushed gravel, consisting of sound, rough, durable pebbles or rock fragments of uniform quality;
- (b) free from clay balls, vegetable matter, or other deleterious matters;
- (c) meets the requirements of Table C-1; and
- (d) meets the requirements of Table C-2, as determined by ATM 304.

#### C07.3 Surface Course

- (a) Is a screened or crushed gravel, consisting of sound, rough, durable pebbles or rock fragments of uniform quality;
- (b) free from clay balls, vegetable matter, or other deleterious matters; and
- (c) meets the requirements of Table C-2, as determined by ATM 304.

**Table C-1: Aggregate Quality Properties for Base Course**

Property	Test Method	Base Course
L.A. Wear, %	AASHTO T 96	50, max
Degradation Value	ATM 313	45, min
Fracture, %	ATM 305	70, min
Plastic Index	ATM 205	6, max
Sodium Sulfate Loss, %	AASHTO T 104	9, max (5 cycles)

**Table C-2: Aggregate Gradations**

Sieve Designation	Subbase	Base Course	Surface Course
1 1/2 inch			100
1 inch		100	
3/4 inch		70 to 100	70 to 100
3/8 inch		50 to 80	50 to 85
No. 4	20 to 60	35 to 65	35 to 75
No. 8		20 to 50	20 to 60
No. 50		6 to 30	15 to 30
No. 200	0 to 10	0 to 6	7 to 13

(Percent Passing By Weight)

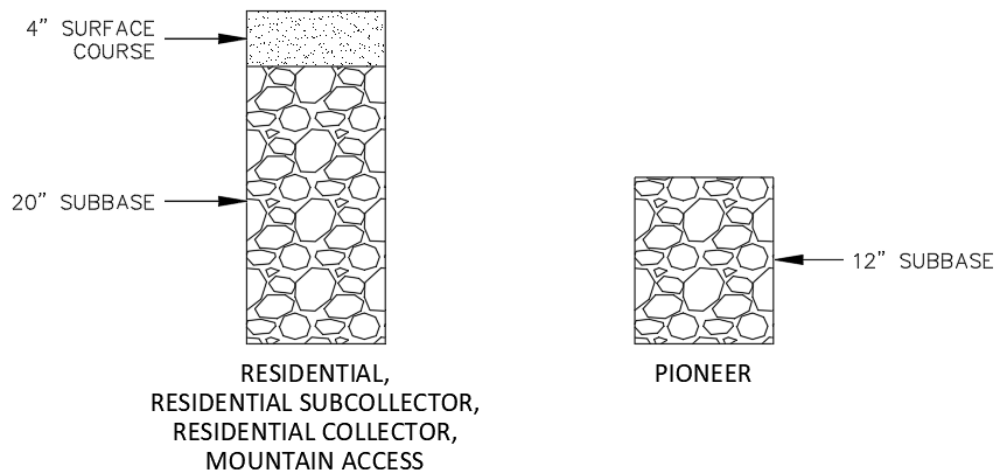

**Figure C-1: Structural Sections for Gravel Roads**

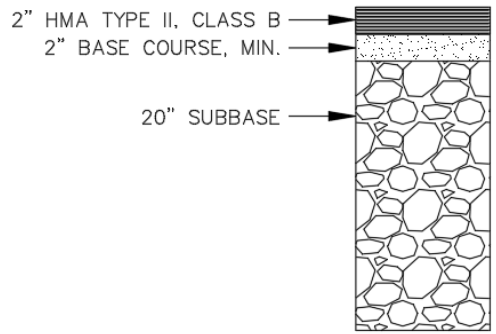

RESIDENTIAL &  
 RESIDENTIAL SUBCOLLECTOR

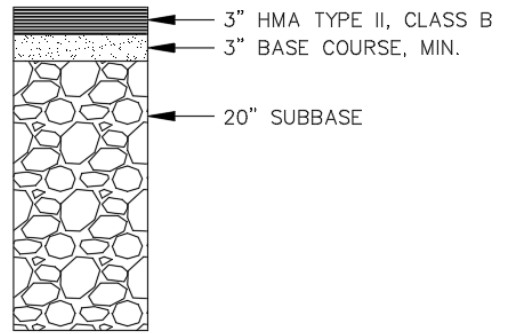

RESIDENTIAL COLLECTOR

**Figure C-2: Structural Sections for Paved Roads**

## Section D. Drainage

### D01 General

The purpose of this section is to ensure that stormwater management is provided with land development activities. Responsible stormwater management is the treatment, retention, detention, infiltration, and conveyance of stormwater and other surface waters without adversely impacting adjoining, nearby, or downstream properties and receiving waters.

### D02 Requirements

A preliminary drainage plan is required when road construction or disturbing land to create useable area for a subdivision is proposed. A drainage report is required for projects that include road construction, disturb 10,000 square feet of land or more, fill in wetlands, disturb land within 100 feet of the ordinary high water mark (OHWM) of a water body, disturb land within a mapped flood hazard area, or change the location, direction, quantity, or type of runoff leaving a site. See subsection D06 for specific requirements regarding fish passage culverts. It is the applicant's responsibility to comply with all other applicable federal, state, and local codes and regulations.

#### D02.1 Preliminary Drainage Plan

Submit a preliminary drainage plan, prepared by an engineer or other qualified professional registered in the State of Alaska, with the preliminary plat or ROW construction permit application. The preliminary drainage plan shall show the project site at a legible scale plottable on 11" by 17" paper or larger and depict the following:

- (a) Existing and proposed property lines, plottable easements disclosed in the title report, the OHWM of water bodies with 100-foot upland offset, and existing mapped flood hazard areas.
- (b) Existing topography with horizontal and vertical accuracy meeting US National Map Accuracy standards, with 5-foot contour intervals if the ground slope is less than 10 percent and 10-foot contour intervals if the ground slope is greater than 10 percent.
- (c) Existing features that convey or retain drainage, including but not limited to: water bodies, wetlands, natural valleys, swales, ditches, check dams, culverts, and pipe systems.
- (d) Proposed drainage pattern and features, both constructed and natural, on site. Identify conveyance types, flow directions, and any drainage changes that may affect adjacent property.
- (e) Proposed stream crossings and anticipated culvert sizes. Identify fish-bearing streams.

#### D02.2 Drainage Report

Submit a drainage report, prepared by an engineer or other qualified professional registered in the State of Alaska, as part of the construction plan submittal in subsection F01.2. The drainage report shall include the following:

- (a) The drainage plan as specified in D02.1 (may be shown on two plans for clarity), updated to include:

- (1) Pre-development and post-development catchment area boundaries determined using 2-foot contour intervals; and
- (2) Locations of peak flow, peak velocity, and where runoff leaves the project site.
- (b) Description of methods, assumptions, and data sources used or made, including but not limited to:
  - (1) Rainfall data from the NOAA-14 Precipitation Frequency Data Server.
  - (2) Assumed post-development land cover conditions.
  - (3) Method used to determine runoff quantities, time of concentration, peak flows, etc.
- (c) Catchment area maps used or created to evaluate down-gradient conditions.
- (d) Identify design elements, with supporting runoff calculations, necessary to show compliance with the drainage design criteria set forth in D03.
- (e) Fish passage culvert plans, if applicable.

### D03 Drainage Design Criteria

- (a) Design a drainage system for the project site to meet the criteria listed in Table D-1.
- (b) Retain natural drainage patterns to the extent possible.
- (c) Changes to drainage patterns must not adversely affect adjacent property or ROW.
- (d) Base the size and capacity of the drainage system on runoff volumes and flow rates assuming full development of the subdivision and a 10 percent increase to runoff from the catchment area.
- (e) Drainage easements are required where the ROW is not sufficient to accommodate drainage needs. See subsection E01.2.
- (f) Where drainage easements overlap utility easements:
  - (1) Above ground drainage facilities, such as retention and detention basins, may be located in new utility easements only in a manner that will not interfere with utilities. See subsection H02.
  - (2) Above ground drainage facilities located within existing utility easements require a letter of non-objection from affected utilities.
  - (3) Culverts crossing utility easements require a letter of non-objection from affected utilities.
  - (4) Underground drainage facilities such as infiltration trenches and vertical inlets shall not be located in utility easements.
- (g) Drainage to state or other municipal ROW are subject to their respective requirements and review.

**Table D-1: Drainage Sizing and Analysis Criteria**

Design Requirement	Purpose	Criteria
Conveyance	Size conveyances to pass design peak flows.	Drainage ditches: 10-year, 24-hour Non-regulated streams: 10-year, 24-hour Regulated streams: 100-year, 24-hour
Wetlands	Retain function of original wetlands	Preserve the pre-development function of wetlands. For jurisdictional wetland areas, comply with United States Army Corps of Engineers wetlands development retention requirements.
Water Quality	Treat first flush pollutant loading	Treat runoff generated by 0.50 inch of rainfall in a 24-hour period.
Erosion and Sedimentation Control	Ensure channel stability for all project conveyances	Control flows in conveyance channels so that transport of particles sized D50 and greater will not occur for the post-development peak flow.
Extended Detention	Protect streams and channels from damage from smaller, more frequent storm flows	Provide 12 to 24 hours of detention for the post-development project runoff in excess of pre-development runoff volume for the 1-year, 24-hour storm.
Flood Hazard	Control peak flow to minimize downstream impacts	Option 1 Maintain the post-development project runoff peak flows from the 10-year, 24-hour storm to less than or equal to pre-development runoff peak flow at all project discharge points.  Option 2 Maintain the post-development project runoff peak flows to less than 1.10 times pre-development runoff peak flow at all project discharge points. Evaluate downstream until the project site area is less than 10% of the total upstream basin area and mitigate adverse impacts.
Flood Bypass	Prevent an increased risk of flood damage from large storm events.	Compute post-development peak flow and delineate an unobstructed, overland flow path for runoff to overtop or bypass project conveyance routes for the post-development 100-year, 24-hour storm.

## D04 Drainage Ditches

Stabilize ditches with gravel, turf, or rock riprap. See Table D-2 and Table D-3 for most common conditions and acceptable ditch lining materials. Evaluate channel stability for compliance with the Erosion and Sedimentation Control design requirement in Table D-1 for other conditions.

Normal ditch depth shall be 30 inches and according to the typical section shown in subsection A06. The design peak flow required by Conveyance Design in Table D-1 shall be conveyed within ditches with a minimum freeboard of 12 inches.

The ditch depth may be reduced at local high points of the ditch, provided the flow line offset is maintained and with DPW concurrence. Alternate ditch design along Residential and Residential Subcollector streets may be considered, if evidence is provided that the following conditions exist:

- (a) Ditches are a minimum of 18" deep;
- (b) The design peak flow required by Table D-1 is demonstrated to be conveyed within ditches with a minimum freeboard of 12 inches;
- (c) Adequate drainage routes are provided and constructed within the ROW or designated drainage easements;
- (d) Flow lines are established at least 8 feet from the edge of roadway.
- (e) Ditches are deepened to provide cross drainage through 24" corrugated metal culverts (18" with DPW approval).
- (f) Cross sectional area of ditch is at least 15 square feet.

**Table D-2: Ditch Stabilization**

Flow (cfs)	Ditch Slope (ft/ft)										
	0.005	0.01	0.02	0.03	0.04	0.05	0.06	0.07	0.08	0.09	0.10
2.0	A	A	A	A	A	A	A	A	A	A	A
4.0	A	A	A	A	A	A	A	A	B	B	B
6.0	A	A	A	A	A	A	B	B	B	B	B
8.0	A	A	A	A	A	B	B	B	B	B	B
10.0	A	A	A	A	B	B	B	B	B	B	C
20.0	A	A	A	B	B	B	C	C	C	C	C
30.0	A	A	A	B	B	C	C	C	D	D	D
40.0	A	A	B	B	C	C	C	D	D	D	E
50.0	A	A	B	B	C	C	D	D	D	E	E
60.0	A	A	B	C	C	D	D	D	E	E	E
70.0	A	A	B	C	C	D	D	E	E	E	E
80.0	A	B	C	C	C	D	E	E	E	E	E
90.0	A	B	C	C	D	D	E	E	E	E	F
100.0	A	B	C	C	D	D	E	E	E	F	F

**Table D-3: Ditch Lining Materials**

Type	Material	D50 (in)	Dmax (in)	Dmin (in)	Thickness (in)
A	Native Grass, Turf, or Gravel with < 6% fines				
B	Riprap or Bone Rock	3.0	4.5	1.5	6.0
C	Riprap or Bone Rock	6.0	9.0	3.0	12.0
D	Riprap or Bone Rock	9.0	13.5	4.5	18.0
E	Riprap or Bone Rock	12.0	18.0	6.0	24.0

## D05 Culverts

### D05.1 General Culvert Design Criteria

The following criteria apply to all cross road culverts for runoff or seasonal drainage:

- (a) The minimum culvert slope is 0.5 percent.
- (b) Culverts longer than 100 feet require appropriate maintenance access and DPW approval
- (c) Cross road culverts shall have a minimum diameter of 18 inches.
- (d) Culverts shall be sized to convey the design peak flow required by Table D-1, based on the larger of the two computed sizes using inlet control and outlet control.
- (e) Culverts shall be corrugated metal pipe (CMP) and minimum:
  - (1) 16 gauge galvanized steel on Residential and Residential Subcollector streets;
  - (2) 12 gauge galvanized steel on Residential Collector and minor collector streets; or
  - (3) 16 gauge aluminum or aluminized if needed due to soil or water conditions.
- (f) Design and install energy dissipation rock aprons at culvert outlets in accordance with Hydraulic Engineering Circular No. 14 (FHWA).
- (g) Install culverts in accordance with the manufacturer’s recommendations for the anticipated traffic loads.

### D05.2 Stream Crossing Culvert Criteria

The following criteria apply to all stream crossing culverts:

- (a) Prior to preliminary plat submittal, contact the Alaska Department of Fish and Game (ADFG), Division of Habitat to determine if a stream reach harbors fish. If so, stream crossing culverts shall be designed, constructed, and maintained according to D06.
- (b) Stream crossing culverts shall be placed as close to the pre-existing channel alignment as possible. Avoid placing culverts at pools and stream bends.
- (c) Road alignment shall be as close to perpendicular to the stream channel as possible.
- (d) Culvert slope shall be within 25 percent of the natural stream slope. For example, if the natural stream slope is 1.0 percent, the minimum design slope of the culvert would be 0.75 percent and the maximum design slope would be 1.25 percent.
- (e) Culvert outlet and inlet protection shall be used as necessary to reduce the risk of scour and perching.

- (f) Stream crossings shall be composed of a single pipe or arch for the main stream channel.
- (g) Overflow culverts may be used but should be placed at a higher elevation so that flows up to the OHWM pass through the primary culvert.
- (h) Stream crossings shall maintain the connectivity of wetlands adjacent to stream channels and shall accommodate sheet flow within such wetlands.
- (i) Stream crossing culverts shall not interfere with the functioning of floodplains and shall be designed to convey the design peak flow required by Table D-1. If the stream crossing culvert is not designed to accommodate the 100-year flow, a route must be established to safely convey flows exceeding the design peak flow without causing damage to property, endangering human life or public health, or causing significant environmental damage.
- (j) In cases of crossings within high entrenchment ratio environments, the ratio of the flood prone width to the OHWM width is greater than 2.2, floodplain overflow culverts may be beneficial to floodplain connectivity and can be used to pass the design flow. Minimum width requirements for the primary culvert still apply.
- (k) Stream crossing culverts shall have a minimum diameter of three feet.
- (l) Stream crossing culvert pipes and arches shall be metal.
- (m) Culverts longer than 100 feet require appropriate maintenance access and DPW approval
- (n) Install culverts in accordance with the manufacturer's recommendations for the anticipated traffic loads.

## D06 Fish Passage Culverts

These criteria provide general design guidance for road crossings of fish-bearing streams to maintain the full hydrologic functioning of the water body they are crossing. Site-specific conditions, such as multi-thread channels, may require alternate design approaches.

### D06.1 Pre-design Conference

Schedule a fish passage pre-design conference with DPW prior to permit submittals. The pre-design conference is to:

- (a) determine required permits;
- (b) coordinate interagency requirements;
- (c) determine any site-specific design requirements; and
- (d) establish a plan review process.

### D06.2 Stream Simulation Method

Stream simulation methodologies shall be used for the design of all fish-bearing stream crossings. The stream simulation method uses reference data from a representative section, or reference reach, of the specific water body crossed. This method attempts to replicate the natural stream channel conditions found upstream and downstream of the crossing. Sediment transport, flood and debris conveyance, and fish passage are designed to function as they do in the natural channel.

### **Reference Reach**

- (a) Select a reference reach on the water body being crossed that is outside any anthropogenic influence, such as an existing culvert. In most cases of new crossings, the reference reach can be at the crossing location.
- (b) The length of the reference reach should be a minimum of 20 times the reference bankfull width and no less than 200 feet.
- (c) If there is not a suitable reference reach on the water body being crossed, a reference reach may be chosen from another water body with similar geomorphic and hydrologic characteristics. The reference reach characteristics should meet the following criteria in comparison to the water body being crossed:
  - (1) The reference reach bankfull width should be at least one half and no more than two times that of the water body being crossed;
  - (2) The reference reach bankfull discharge should be at least one half and no more than one and one half times the bankfull discharge of the water body being crossed; and
  - (3) The stream order of the reference reach should be within one stream order of the water body being crossed.
- (d) For a reference reach from another water body, the geomorphic characteristics of the crossing shall be scaled using ratios of the bankfull conditions.
- (e) The reference reach bankfull dimensions should be determined in the field by surveying a detailed cross section at the upper 1/3 of a representative riffle.
- (f) Reference data shall include, at a minimum:
  - (1) channel width at the OHWM,
  - (2) bankfull width,
  - (3) bankfull cross-sectional area,
  - (4) bankfull slope based on the longitudinal profile,
  - (5) substrate, and
  - (6) potential for floating debris.

### **Culvert Size, Slope, and Substrate**

In addition to D05.2, the following criteria apply to fish passage culverts:

- (a) Under normal flow conditions, the channel within or under the fish passage culvert shall not differ from the reference reach condition in regards to the channel width at the OHWM, cross-sectional area, slope, substrate, and ability to pass floating debris.
- (b) The width of fish passage culverts shall not be less than the greater of 1.2 times the channel width at the OHWM and 1.0 times the bankfull width.
- (c) Fish passage culverts shall have a minimum diameter of five feet.
- (d) The use of smooth wall culverts is prohibited.
- (e) The use of trash racks or debris interceptors is prohibited
- (f) Round culvert pipes shall have a minimum invert burial depth of 40 percent of the culvert diameter into the substrate. Arch or box culverts shall have a minimum invert burial depth of 20

percent of the culvert's rise into the substrate, unless scour analysis shows less fill is acceptable. The minimum invert burial depth is 1 foot.

- (g) The gradation of the substrate material within a fish passage culvert shall be designed to be a dense, well-graded mixture with adequate fines to ensure that the majority of the stream flows on the surface and the minimum water depth is maintained.
- (h) Substrate material within or under the fish passage culvert shall remain dynamically stable at all flood discharges up to and including a 50-year flood. Dynamic stability means that substrate material mobilized at higher flows will be replaced by bed material from the natural channel upstream of the crossing. For crossings without an adequate upstream sediment supply, the substrate material within the crossing shall be designed to resist the predicted critical shear forces up to the 100-year flood. For culverts with a slope of 6 percent or greater, substrate retention sills may be required to allow the bed load to continuously recruit within the culvert.
- (i) Substrate material within or under the fish passage culvert shall incorporate a low flow channel. The low flow channel should mimic the reference reach where possible. If the low flow channel dimensions are not discernable from the reference reach, the low flow channel should have a cross sectional area of 15 to 30 percent of the bankfull cross sectional area and a minimum depth of 4 inches for juvenile fish and 12 inches for adult fish. The low flow channel should be defined by rock features that will resist critical shear forces up to the 100-year flood.
- (j) Constructed streambanks are recommended inside fish passage culverts to protect the culvert from abrasion, provide resting areas for fish, and provide for small mammal crossing. If streambanks are constructed through a crossing, the streambanks shall be constructed of rock substrate designed to be stable at the 100-year flood. The streambank width should be a minimum of 1.5 times the maximum sieve size of the streambed material (D100). The crossing width shall be increased to allow for the channel width plus the streambanks.
- (k) If substrate retention sills are used, they shall have a maximum weir height of one half of the culvert invert burial depth. Substrate retention sills shall be spaced so that the maximum drop between weirs is 4 inches. The use of sills without substrate is not allowed.
- (l) Other state and federal requirements may apply.

### D06.3 Hydraulic Method

Hydraulically designed culverts are discouraged for fish-bearing stream crossings, though may be approved by DPW and ADFG in circumstances where stream simulation is not practical. In addition to D05.2, the following criteria apply to hydraulically designed culverts:

- (a) The hydraulic method uses the swimming capability and migration timing of target design species and sizes of fish to create favorable hydraulic conditions throughout the culvert crossing. Information and design software for this methodology is available from ADFG, Division of Sport Fisheries (Fishpass) and the US Forest Service (FishXing).
- (b) The design fish shall be a 55-milimeter (2.16-inch) juvenile coho salmon for anadromous streams and a 55-milimeter (2.16-inch) Dolly Varden char for non-anadromous streams. These criteria may change based on ongoing research by federal and state agencies.

- (c) Fish passage high flow design discharge will not exceed the 5 percent annual exceedance flow or 0.4 times the 2-year peak flow, whichever is lower and has the most supporting hydrologic data.
- (d) Fish passage low-flow design discharge shall ensure a minimum 6-inch water depth or natural low flow and depth within the reach the crossing occurs. In cases where local conditions preclude natural low flow characteristics, backwatering or in-culvert structures should be considered.
- (e) In cases where flared end sections with aprons are necessary and fish passage is required, water depths and velocities that satisfy fish passage criteria must be demonstrated across the apron in addition to within the culvert.
- (f) Fish passage criteria for culverts crossing tidally-influenced streams must be satisfied 90 percent of the time. Tidally-influenced streams may sometimes be impassable due to insufficient depth at low flow and low tide. If the tidal area immediately downstream of a culvert is impassable for fish at low tide, the exceedance criterion shall apply only to the time during which fish can swim to the culvert.
- (g) Other state and federal requirements may apply.

## D07 Soil Infiltration Facilities

Soil infiltration may be used to reduce stormwater flow and volume with the following criteria:

- a) Soil infiltration facilities within Borough ROW or drainage easements should be designed such that they are not considered Class V injection wells. See Appendix A for the EPA's memorandum addressing the subject in June 2008.
  - (1) Private drainage facilities that are considered Class V injection wells require conformance with EPA regulations.

## D08 Rainfall Data

### D08.1 Rainfall Distribution

Intensity-Duration-Frequency (IDF) and 24-hour rainfall data are furnished by NOAA Atlas 14 Point Precipitation Frequency Estimates. Use SCS Type-I Rainfall Distribution and 24-hour rainfall depth to compute runoff.

### D08.2 Runoff Transformation

Use the Rational Method for estimating peak flows in drainage basins less than 200 acres and with times of concentration less than 20 minutes for design of conveyances. Use NRCS (SCS) Unit Hydrograph Method for estimating runoff volumes and peak flows for other conditions and applications. Other methods more appropriate for site conditions may be utilized upon DPW approval.

## Section E. Easements

### E01 General

#### E01.1 Common Access Easements

When a shared driveway is required for two or more lots, a common access easement shall be granted for the exclusive use of the subject lots, unless otherwise accommodated. The common access easement shall be sized to reasonably accommodate separation of the shared driveway to the individual lots.

#### E01.2 Drainage Easements

Drainage easements are required where the ROW is not sufficient to accommodate drainage needs. Drainage easements can overlap with other platted easements and shall begin or terminate at the ROW. Drainage easements shall be a minimum width of 20 feet, and a minimum average length of 20 feet outside of any overlapping easements or of sufficient size and area shown to facilitate construction and maintenance.

#### E01.3 Slope Easements

Slope easements are required to contain all cut and fill slopes steeper than 2.5:1 that extend outside of the ROW, plus at least 5 feet outside the cut or fill catches.

#### E01.4 Sight Distance Maintenance Easements

Sight distance maintenance easements are required where intersection sight triangles extend outside of the ROW.

#### E01.5 Snow Storage Easements

Snow storage easements are required where the ROW is not sufficient to accommodate anticipated snow removal needs. Snow storage easements shall be located where the storage of snow would not impede sight distance.

#### E01.6 Utility Easements

Unless lots are otherwise served by alternate utility easements or agreements, at least one 15-foot utility easement adjacent to the ROW is required to allow for utility installation and maintenance. Additional utility easements may be required as deemed reasonably necessary by utility companies to serve the subdivision or protect existing facilities. The applicant is responsible for satisfying any conflicts that may occur in the request for easements from any utility company during the platting process.

Platted utility easements are to be clear of wells, septic systems, structures, or encroachments, as defined by MSB or other applicable code; unless the applicant has obtained an encroachment permit from the MSB and a "Non-Objection to Easement Encroachment" from each utility.

Utility easements are to be fully useable for utility installation where installation equipment can safely work. Whenever possible, utility easements should not be placed in swamps, steep slopes, or other unusable areas.

## Section F. Development Implementation

### F01 General

This section describes the procedure that is to be followed before constructing any improvements required for recording a subdivision plat. The applicant's engineer shall be the primary point of contact throughout this process.

It is the applicant's responsibility to determine, acquire, and follow permits required by other agencies. Approval from MSB does not supersede other agencies' permit requirements.

#### F01.1 Preliminary Plat Submittal

The preliminary plat submittal is to be accompanied by:

- (a) ADT calculations per A15;
- (b) Preliminary drainage plan per D02.1;
- (c) Road plan and profile for sections of road where proposed grades exceed 6 percent where cuts and fills exceed 5 feet in height measured from the centerline, or where slope easements will be required, and cross sections at the maximum cut and fill sections. Road plan and profile shall include the vertical curves or grade breaks on either side of the subject sections;
- (d) Road plan, profile, and cross-sections if required by B03.3; and
- (e) Intersection sight distance evaluation, if requested, according to A09.1.

#### F01.2 Construction Plans

Submit construction plans to DPW at least seven calendar days before the preconstruction conference. All plan drawing submittals shall be at a scale of 1 inch = 50 feet or more detailed, plottable on 11" by 17" paper. Construction plans shall include the following:

- (a) Drainage Report, according to D02.2;
- (b) Plan & Profile of proposed roads (if required by F01.1);
  - (1) Existing topography with horizontal and vertical accuracy meeting US National Map Accuracy standards, two-foot contour intervals within the proposed road corridors.
- (c) Asbuilt survey of visible improvements and above ground utilities within and adjacent to the subdivision;
- (d) Copy of agency accepted permit applications required for the improvements prior to construction, including but not limited to ADOT&PF Approach Road Permit, DNR Section Line Easement authorization, MSB Flood Hazard Development permit, and USACE wetland fill permit; and
- (e) Plans for any proposed improvements within the ROW that are outside of the scope of this manual (e.g. retaining walls or guard rail) or do not conform to the standards set forth herein, conforming to ADOT&PF design criteria and standards.

### F01.3 Preconstruction Conference

The preconstruction conference is for the purpose of reviewing and approving the Subdivision Construction Plan for the required improvements. The engineer may request scheduling of a preconstruction conference with DPW after the preliminary plat has been approved by the Platting Board, the Platting Board Action Letter has been received, and the construction plans have been submitted. Scheduling of preconstruction conference requests may be delayed during the month of October. The applicant, or designated representative, and the engineer must attend the preconstruction conference. In addition to the construction plans, the following items will be provided at or prior to the preconstruction conference:

- (a) Cost estimate of required improvements for the determination of the inspection fee according to the most recently adopted Schedule of Rates and Fees;
- (b) Proof of compliance with the Alaska Pollutant Discharge Elimination System Program;
  - (1) Acceptable proof includes a Notice of Intent (NOI), a Low Erosivity Waiver (LEW), or a determination by a qualified person that neither is needed.
- (c) Rough plan and time line for construction;
- (d) Copy of any issued permits required for the improvements prior to construction;
- (e) Off-site material source and quantities; and
- (f) On-site clearing, grubbing, and topsoil disposal plan, location map.

The Subdivision Construction Plan must be signed by the applicant, or designated representative, and the engineer. Upon acceptance of the Subdivision Construction Plan by DPW and payment of the inspection fee, the Platting Division will issue a Notice to Proceed (NTP).

Some construction plans or permit approvals may take longer to develop or obtain, such as fish passage culvert plans and associated permits. Those finalized plans and issued permits may be submitted later but must be received and reviewed by DPW before construction begins within the respective areas.

### F01.4 Interim Inspections

The applicant's engineer shall supervise all phases of construction. Notify DPW of changes to the Subdivision Construction Plan, such as adding or deleting a cross culvert, changes in culvert size, adding or deleting a drainage facility, grade changes of more than 1 percent or that would result in grades of over 6 percent or cuts or fills of over 5 feet in height measured from the centerline, or changes to foreslopes or backslopes. The changes should be approved by DPW prior to completion of construction. Periodic interim inspections may be conducted by DPW. Interim inspections may be requested by the engineer.

### F01.5 Subdivision Agreements

If a developer wishes to enter into a Subdivision Agreement and the requirements of MSB 43.55.010(A) are met, the Engineer shall submit a request to DPW no later than October 15<sup>th</sup> for an Interim Inspection. The Interim Inspection shall be attended by the engineer and DPW, and a list of remaining improvements and work items will be developed. The engineer shall then submit a request for a

Subdivision Agreement containing the scope of work, quantity estimates, and cost estimate in accordance with MSB 43.55 to Platting and for approval by DPW. DPW will only approve the request for a subdivision agreement if all of the minimum required improvements have been inspected by October 31<sup>st</sup> or before winter conditions prohibit inspection, whichever comes first.

#### F01.6 Pre-Final Inspection

When the engineer has determined that construction of the improvements will be substantially complete according to the Subdivision Construction Plan, the engineer will request a Pre-Final Inspection. The Pre-Final Inspection request must be received by September 30<sup>th</sup> and shall include a description of work yet to be completed. The Pre-Final Inspection will be scheduled to occur within 14 calendar days of the request and shall be attended by the engineer and DPW. A punch list will be developed, if any work items remain, at the Pre-Final Inspection.

#### F01.7 Final Inspection

When construction of the improvements and punch list items are complete according to the Subdivision Construction Plan, the engineer will request a Final Inspection of the improvements. The Final Inspection request must be received by October 15<sup>th</sup>. Final Inspections will cease October 31<sup>st</sup>, or when winter conditions prohibit inspection, whichever comes first. The Final Inspection will be scheduled to occur within 14 calendar days of the request and shall be attended by the engineer and DPW.

#### F01.8 Final Report

Upon DPW approval of the Final Inspection, the engineer shall submit a written Final Report to the Platting Division. The Final Report shall include:

- (a) Stamped and signed narrative describing at a minimum:
  - (1) road construction process and equipment used,
  - (2) material source and disposal areas,
  - (3) road embankment and subbase used,
  - (4) road topping or pavement used,
  - (5) compactive effort,
  - (6) road dimensions and shaping (length, roadway width, material thicknesses, pavement width, crown, cul-de-sac or t-turnaround dimensions and slope, foreslope, backslope, maximum centerline grade, etc.) for each road constructed,
  - (7) drainage, ditch depth, location of drainage easements, and
  - (8) road standard certification (Pioneer Road, Residential Street, etc.) for each road constructed;
- (b) Stamped and signed final drainage plan, (minimum 11"x17");
- (c) As-built drawing showing the horizontal locations of borrow extraction along the road corridor;
- (d) Documentation verifying Surface Course thickness such as photos and descriptions of test pits, scale tickets, asbuilt surveys, or alternative methods approved by DPW;
- (e) Compaction test reports;
- (f) Gradation tests, if required; and

(g) Photos of each stage of construction.

DPW will review the report and provide comments, if necessary, within 14 calendar days.

#### F01.9 Construction Acceptance

Upon approval of the Final Report, DPW will issue a Certificate of Construction Acceptance.

#### F01.10 Warranty

All improvements are to be guaranteed until October 31<sup>st</sup> of the calendar year following DPW approval of the Final Inspection. Roads within a Road Service Area may be accepted for maintenance at the end of the warranty. Pioneer Roads are not eligible for maintenance. Maintenance of Mountain Access Roads is at the discretion of DPW.

During the warranty period, the applicant is responsible for any road maintenance including, but not limited to: snow removal, maintaining a smooth road surface and crown, maintaining stabilized foreslopes and backslopes, and maintaining positive drainage. If any deficiencies arise during the warranty, DPW will issue a punch list to the applicant by September 1<sup>st</sup> to allow time for completion of repairs. The applicant must notify DPW of completion of repairs by October 15<sup>th</sup> for the roads to be eligible for maintenance on November 1<sup>st</sup>.

The warranty period for improvements following completion of a subdivision agreement may be lessened to one calendar year. The applicant shall request a punch list from DPW no more than one month before the end of the one-year warranty.

If the subdivision plat has not recorded by April 30<sup>th</sup> or if warranty repairs are not completed by October 15<sup>th</sup>, the warranty will be extended an additional year and the warranty process will be repeated.

Maintenance may be denied and the Certificate of Construction Acceptance revoked if deficiencies are not corrected to the satisfaction of DPW. A notice may be recorded indicating to the public that the MSB is not responsible for road upkeep and maintenance until such a time that the deficiencies are corrected.

## Section G. Commercial and Industrial Subdivisions

### G01 General

Commercial and Industrial subdivisions shall be designed using trip generation rates from the Institute of Transportation Engineers (ITE) Trip Generation Manual, and to meet the standards of AASHTO, International Fire Code (IFC), and any other applicable standards or code.

## Section H. Utilities

### H01 General

These standards apply to the design and construction of utility facilities within the MSB. All utility installation within existing or proposed ROW or utility easements must comply with the provisions of MSB or other applicable code, or as otherwise approved by the permitting authority.

### H02 Utility Location Guidelines

#### H02.1 Underground Utility Facilities:

- (a) The location of utility facilities placed within the ROW shall be coordinated with the permitting authority.
- (b) Backslopes or foreslopes which extend into a utility easement should not exceed 4:1. These limits are necessary for construction equipment for utility installation.
- (c) Utility facilities paralleling the road shall not be located within 10 feet of the roadway, unless otherwise approved by the permitting authority.
- (d) Underground road crossings shall be buried a minimum of 48 inches below finished grade. Backfill shall be compacted according to the requirements of Section C, or as otherwise approved by the permitting authority.
- (e) Conduit road crossings, if used, shall be installed in accordance with each utility company's standards and applicable code.
- (f) Standard burial depth of longitudinal utilities is 36 inches below grade. The applicant should delineate areas, such as where driveways and drainage easements are planned, where deeper burial may be needed.

#### H02.2 Above Ground Utility Facilities:

- (a) Above ground pedestals, poles, and utility facilities shall not be located within 10 feet of the roadway, unless an alternate design meets clear zone requirements.
- (b) Above ground pedestals, poles, and utility facilities shall not be located such that they substantially block intersection or driveway sight triangles.
- (c) Unless otherwise authorized by the permitting authority, above ground pedestals, poles, and utility facilities shall not be located within the ROW nearer than 40 feet from the point of intersection of the extension of the property lines at any existing or proposed intersection on Residential Collector streets or higher classification.
- (d) Above ground pedestals, poles, and utility facilities shall not be located within a common access easement or drainage easement, within 20 feet of a common access point, or within 10 feet of a roadway cross culvert.
- (e) Permanent 5-foot high snow marker poles, grey with white retroreflective sheeting or yellow, shall be installed on all pedestals and vaults.
- (f) All guy wires installed within the ROW or utility easements adjacent to, or near to a roadway shall have a minimum 8-foot long yellow delineator installed above the anchor.

(g) Pedestals located within the ROW shall be located within the outer 1 foot of the ROW.

#### H02.3 Separation of Utilities:

- (a) Recommend 5-foot horizontal separation between power poles and buried utilities.
- (b) Recommend minimum 1-foot physical separation between all underground utilities.
- (c) Separation of storm, sewer, and water utilities shall meet the requirements of the Alaska Department of Environmental Conservation.

## References

- American Association of State Highway and Transportation Officials. (2018). *A Policy on Geometric Design of Highways and Streets* (7<sup>th</sup> ed.). Washington, DC.
- American Association of State Highway and Transportation Officials. (2011). *Roadside Design Guide* (4<sup>th</sup> ed.). Washington, DC.
- American Association of State Highway and Transportation Officials. (2017). *Guide for the Development of Bicycle Facilities* (4<sup>th</sup> ed.). Washington, DC.
- Alaska Department of Transportation & Public Facilities. (2019). *Alaska Highway Preconstruction Manual*. Juneau, AK.
- Alaska Department of Transportation & Public Facilities. (2017). *Alaska Standard Specifications for Highway Construction* (2017 ed.). Juneau, AK.
- Alaska Department of Transportation & Public Facilities. (2015). *Alaska Sign Design Specifications*. Juneau, AK.
- Alaska Department of Transportation & Public Facilities. (2007). *Alaska Test Methods Manual*. Juneau, AK.
- Alaska Department of Transportation & Public Facilities. (2016). *Alaska Traffic Manual*. Juneau, AK.
- Alaska Railroad. (1988). *Alaska Policy on Railroad/Highway Crossings*. Anchorage, AK.
- Alaska Society of Professional Land Surveyors. (2013). *Standards of Practice Manual*. (4<sup>th</sup> ed.). Anchorage, AK.
- Institute of Transportation Engineers. (2017). *Trip Generation Manual*. (10<sup>th</sup> ed.). Washington, DC.
- Matanuska-Susitna Borough. (2017). *Matanuska-Susitna Borough Long Range Transportation Plan*. Palmer, AK.
- Matanuska-Susitna Borough. (2007). *Matanuska-Susitna Borough Official Streets and Highway Plan*. Palmer, AK.
- Matanuska-Susitna Borough. (2019). *Matanuska-Susitna Borough Standard Modifications to State of Alaska Standard Specification for Highway Construction* (2017 ed.). Palmer, AK.
- U.S. Department of Transportation Federal Highway Administration. (2012). *Manual of Uniform Traffic Control Devices for Streets and Highways* (2009 ed. with 2012 revisions). Washington, DC.

## Appendix A

Environmental Protection Agency Memorandum - Class V Injection Wells



## Design Criteria Manual

### Chapter 2: Bridges & Crossing Culverts

Public Works Department

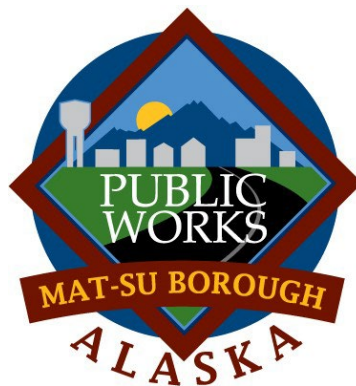



## TABLE OF CONTENTS

1	Scope .....	1
2	References .....	1
3	General .....	2
3.1	Traffic Volume, Design Speed and Functional Geometry .....	2
3.2	Survey .....	3
3.3	Accident Analysis .....	3
3.4	Geotechnical Field Work and Foundation Report .....	3
3.5	Hydraulics and Hydrology .....	4
3.6	Permitting and Environmental .....	4
3.7	Pathways on Bridges .....	5
3.8	End Terminals, Approach Guard Railing, and Transition to Bridge Rail .....	5
3.9	Signage, Marking, and Striping .....	5
3.10	Durability and Corrosion Control .....	6
3.11	Study Phase Submittals .....	6
3.12	Design Phase Submittals .....	7
4	Hydraulics and Hydrology .....	7
4.1	General .....	7
4.2	Hydraulic Site Survey and Site information .....	8
4.3	Hydraulic History of the Site .....	8
4.4	Design Flood Event .....	8
4.5	Scour Analysis .....	9
4.6	Ice Analysis .....	9
4.7	Clearance .....	9
4.8	Abutment and Bank Protection .....	9
4.9	Fish Passage Analysis .....	9
4.10	Storm Water Drainage .....	10
5	Structural .....	10
5.1	General .....	10
5.2	Deck .....	10
5.3	Superstructure .....	11
5.4	Substructure .....	11
5.5	Use of preservative-treated wood .....	12
5.6	Bridge rail .....	12
5.7	Design live loads .....	12
5.8	Seismic – special requirements .....	13
5.9	Skewed bridges .....	14
5.10	Use of railcars and other non-bridge structures .....	14
5.11	Welding .....	15
6	Stream Crossing Culverts .....	15
6.1	General Requirements .....	15
6.2	Fish Passage Culverts .....	16

7 Appendices ..... 19  
7.1 Appendix 1 - Bridge Final Design Check List..... 19

## 1 Scope

This Manual shall be used for design and construction of all new bridges, and stream crossing culverts<sup>1</sup> and replacement bridges and culverts within the Matanuska-Susitna Borough (MSB) right-of-way (ROW), easements, on public property and in subdivisions with private streets, except in the cases listed below. In this document the word “bridges” is intended to refer to both bridges culverts that cross streams, pathway tunnels or other large diameter structural pipes, unless otherwise noted.

This manual does not apply to the design or construction of:

- Bridges within the jurisdiction of the Alaska Department of Transportation and Public Facilities (DOT&PF). This includes bridges on State roads.
- Bridges on private property (except as noted for subdivisions with private streets)
- Existing bridges

## 2 References

The following design guidelines, manuals, and standards are referenced in this Manual. Use the editions—with all amendments, revisions, provisions, and modifications—published at time of contract execution:

American Association of State Highway and Transportation Officials (AASHTO):

*“A Policy on Geometric Design of Highways and Streets” (GB)*

*“Design Guide for Very Low Volume Roads (GDVLVLR)”*

*“Load and Resistance Factor Design (LRFD) Bridge Design Specifications (BDS)”*

*“Guide Specification for LRFD Seismic Bridge Design”*

*“Manual for Bridge Evaluation”*

*“Guide for the Development of Bicycle Facilities”*

*“Drainage Manual”*

DOT&PF:

*“Alaska Highway Drainage Manual”*

*“Alaska Traffic Manual” (ATM)*

*“Pre-construction Manual (HPCM)”*

*“Standard Specifications for Highway Construction (SSHHC)”*

Federal Highway Administration (FHWA):

*“Manual on Uniform Traffic Control Devices (MUTCD)”*

---

<sup>1</sup> Although culverts less than 20 feet in diameter and other bridge-like structures less than 20 feet long (in the direction of traffic or structure span) are not considered “bridges” by the FHWA and AASHTO, the provisions of this Manual are to be applied to such elements.

U.S. Fish and Wildlife Service (USFWS):  
“Culvert Design Guidelines for Ecological Function”  
“Stream Simulation Guidelines”

Other:  
National Cooperative Highway Research Program (NCHRP) 350 Report: “Recommend procedures for the safety performance evaluation of highway features”

Western Wood Preservers Institute, “Best Management Practices (BMPs) for the Use of Treated Wood in Aquatic and Other Sensitive Environments”

### 3 General

A number of general studies, reports, and submittals are required in the planning and design of all new bridges. These include but are not limited to traffic volume, classification, design speed and functional geometry, utility and ROW surveys, accident analysis, geotechnical, hydraulics/hydrology, permitting and environmental, and corrosion control. These items shall be subject to approval by the MSB Department of Public Works (DPW) Director.

#### 3.1 Traffic Volume, Design Speed and Functional Geometry

The MSB will provide the Average Daily Traffic (ADT), Annual Average Daily Traffic (AADT), and design speed for each new crossing.

Grade, alignment, and sight distance shall meet the requirements of “A Policy on Geometric Design of Highways and Streets.” Design speed shall match the approach roadway design speed.

The clear roadway width<sup>2</sup> on the bridge shall be not less than the value from Table 4.1. NOTE: Table 4.1 is applicable only to “Local Roads and Streets” and “Collector Roads and Streets”, as defined in “A Policy on Geometric Design of Highways and Streets”. For “Urban and Rural Arterials” and “Freeways” follow the guidance in “A Policy on Geometric Design of Highways and Streets”.

**Table 4.1 Minimum clear roadway width on bridge**

ADT	Total crossing length <sup>3</sup> (feet)	Minimum clear roadway width (feet)
≤ 2000	Any length	Approach roadway width <sup>4</sup> , but not less than 28 feet
> 2000	≤ 100 feet	Approach roadway width, but not less than 30 feet
> 2000	> 100 feet	Traveled way + 3 ft (each side) <sup>5</sup> , but not less than 30 feet

<sup>2</sup> Clear roadway width is the distance between the inside face of curbs or vehicular railings, whichever is less.

<sup>3</sup> Total crossing length is the distance between “begin bridge” and “end bridge” stations measured along stationing.

<sup>4</sup> Approach roadway width is the distance curb-to-curb or traveled way plus shoulder width.

<sup>5</sup> On long bridges, where the cost per foot is greater than short bridges, narrower widths are usually considered acceptable.

Vertical clearance between the lowest member of the bridge structure and the water surface shall be in accordance with Section 4.7 of this manual. Provide clearance for vessel traffic if the waterway is navigable.

Vertical clearance between the top of the bridge roadway and any overhead cable or structure shall be at least 16 feet 6 inches. This criterion is unique to the MSB.

Design the bridge to support existing and future utilities.

See Section 3.7 for pathway requirements.

### **3.2 Survey**

A survey shall be performed for each new bridge. This shall include the location of all adjacent property and structures, the location of the roadway including centerline (CL), edge of pavement, side slopes and ditches, ordinary high water (OHW), and other features as required. Provide the basis of survey including coordinate system, north arrow, survey monuments and project datum elevation. The survey shall also include the location of all above and below ground utilities in the vicinity (typically 200 feet) of the crossing. The survey shall clearly show the ownership of each parcel and any existing or proposed right-of-way at the proposed crossing.

The survey drawing shall be signed and sealed by a Professional Land Surveyor (PLS) registered in the State of Alaska.

### **3.3 Accident Analysis**

If the new bridge will be replacing an existing bridge the designer will conduct an accident analysis. The designer will examine accident reports from the existing bridge and approaches going back 10 years. The report will summarize the number of accidents and discuss possible contributing factors such as geometry, speed limits, sight distance and other factors.

The accident analysis shall be signed and sealed by a Professional Engineer registered in the State of Alaska.

### **3.4 Geotechnical Field Work and Foundation Report**

A geotechnical field exploration program shall be conducted for each crossing and a foundation report shall be provided.

*Exception:* a field program and report are not required for culverts less than 48 inches in diameter.

Exploratory holes deeper than the foundation elements shall be advanced. The foundation report shall include the types of material found in the field exploration, historical geotechnical information, the bearing capacity of the soils, abutment design guidelines, pile design guidelines (if a pile foundation is selected) including pile capacity with scour allowance, and other items. The geotechnical work shall meet the requirements outlined in the BDS and the *"Pre-construction Manual."* Coordinate with the engineer responsible for the hydraulics and hydrology analyses.

The foundation report shall be sealed by a Professional Engineer registered in the State of Alaska.

### **3.5 Hydraulics and Hydrology**

A hydraulics and hydrology study shall be conducted for each new crossing. This shall include a hydraulic site survey. The details of this are covered in Section 5 of this document.

### **3.6 Permitting and Environmental**

A permitting and environmental study shall be completed for each new crossing. This report shall outline all permits and environmental issues related to the project along with an action plan to obtain the required permits and to mitigate any impacts. All applicable required permits shall be identified. These include but are not limited to:

- United States Coast Guard (USCG) Section 9 Bridge Permit
- United States Army Corps of Engineers (USACE) Section 10 Navigable Waterways
- USACE Section 401 Water Quality
- USACE Section 404 Excavation and/or fill in waters of the US
- Alaska Department of Fish and Game (ADF&G) Title 16 Fish Habitat
- Alaska Department of Natural Resources (DNR) Land Use
- Environmental Protection Agency (EPA) Storm Water Pollution Prevention Plan (SWPPP)
- MSB Flood Plain Development Permit
- MSB ROW Permit

In addition, construction impacts shall be considered in the planning stage. These include but are not limited to:

- Erosion, sediment, and silt containment
- Dust control
- Noise control/abatement
- Channel diversion
- Temporary stream crossing
- Dewatering criteria
- Staged construction, detour route or structures, traffic control

A written permitting and environmental study outlining the above and additional items as applicable to the specific crossing shall be submitted in the planning stages of the project.

### **3.7 Pathways on Bridges**

The full width of any existing sidewalks, pathways, bike lanes, equestrian lanes, or shared-use pathways on the roadway being served shall be continued over the new bridge. If no such pathways exist, the MSB will identify bridge pathway requirements. The minimum width of a pathway on a bridge shall be ten feet. If the expected volume of traffic on the pathway is very low and the bridge is short, the minimum width may be reduced to six feet<sup>6</sup>.

Grating, manhole covers, and other items shall be bicycle and pedestrian “safe” as outlined in the *“Guide for the Development of Bicycle Facilities.”*

All pathways on the bridge shall be signed and striped as outlined in the MUTCD.

Railings, fences, or barriers on each side of a pathway shall be a minimum of 4.5 feet high.

### **3.8 End Terminals, Approach Guard Railing, and Transition to Bridge Rail**

Provide end terminals, approach guard railing, and guardrail-to-bridge rail transitions in accordance with the *“Pre-Construction Manual.”*

See Section 5.6 for bridge rail requirements.

### **3.9 Signage, Marking, and Striping**

All bridges shall be marked and signed as outlined in the ATM. In certain cases this may include:

- Narrow bridge
- Speed restrictions
- Load limits

Identify all bridges with a number assigned by the DOT&PF. The bridge number and year of construction shall be displayed on a bronze plate as shown in Figure 4.9, permanently affixed to the structure near each end, on the right-hand side of approaching traffic. The exact location of plates will be determined by the MSB.

---

<sup>6</sup> In the absence of other published criteria or a specific directive from the MSB, the minimum width may be reduced to six feet if the ADT is less than 400 and the bridge length is less than 40 feet.

**Figure 4.9 – Bronze bridge number plate - example**

Use bronze conforming to American Society of Testing Materials (ASTM) B98, Alloy “A” or “B”. Use “Century” font. Braze  $\frac{1}{4}$ ” diameter threaded rod to back of plate. Use locking nut or lock washers with nuts. Rod and hardware shall conform to Unified Numbering System (UNS) C65100 or C65500.

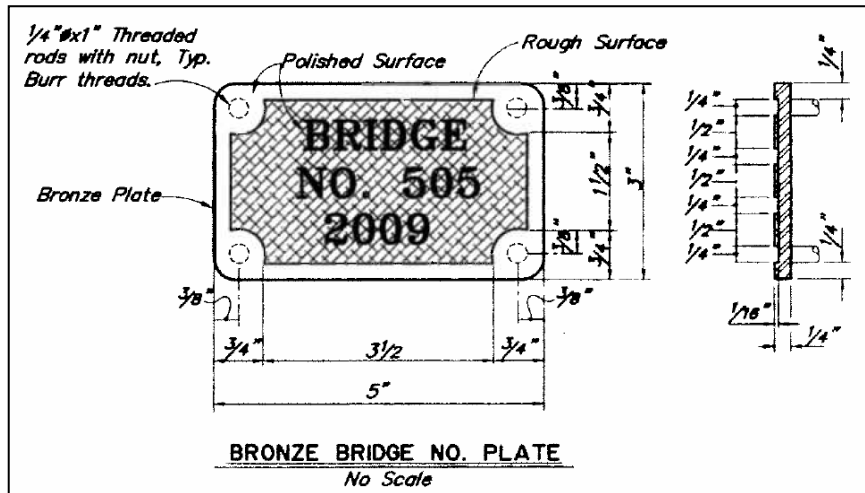

**3.10 Durability and Corrosion Control**

Comply with BDS requirements for durability. All new bridges shall be evaluated for corrosion control requirements. Structural steel members shall be coated, galvanized or constructed from weathering steel. Provide coated or galvanized reinforcing bars in concrete components subjected to deicing salts or salt water. Provide adequate concrete cover and/or membranes to protect reinforcing bars. Provide positive drainage to direct runoff from the deck away from beam seats, bearings, and other structural members. If foundation members are located in tidal-influenced saltwater or brackish water, provide a cathodic protection system such as sacrificial anodes or other means of protection. The geotechnical report shall address the corrosivity of soil and ground water and their effects on foundation elements.

A written corrosion control study outlining the above and additional items as applicable to the specific crossing shall be submitted in the preliminary design stage of the project.

**3.11 Study Phase Submittals**

Provide study phase submittals to the MSB DPW. Study phase submittals are subject to DPW approval and shall include:

- Survey of existing site along with proposed new structure location
- Accident analysis
- Foundation report
- Hydraulic and hydrology report
- Permitting and environmental study

### 3.12 Design Phase Submittals

Provide design phase submittals to the MSB DPW. Design phase submittals are subject to DPW approval and shall include:

- Preliminary design with functional geometry and load ratings
- Structural computations
- Corrosion control study
- Erosion and sediment control plan (ESCP)
- Final design drawings and specifications
- Record or as-built drawings
- Engineer's estimate of quantities and cost

A Professional Engineer registered in the State of Alaska and proficient in bridge engineering shall seal all final bridge design documents, including drawings, special provisions, and structural computations.

## 4 Hydraulics and Hydrology

### 4.1 General

Stream crossing structures must provide for the passage of flood flows, ice movement, sediment transport, debris transport and fish passage. In addition, the design must protect the bridge foundation, adjacent stream banks, and not present a safety hazard to people. In recent years, due to the failure of bridges from scoured foundations during large flood events, the National Transportation Safety Board (NTSB) has placed increased emphasis on special attention to design and maintenance of scour processes in the vicinity of bridge foundations.

Conform to the requirements of the following publications:

- *Alaska Highway Drainage Manual*<sup>7</sup>
- BDS<sup>8</sup>

The design process shall include hydraulic and hydrologic studies and assessment as a part of the preliminary plan development. At a minimum, this shall include the following elements:

- A site-specific hydraulic survey including cross sections,
- Identifying the hydraulic history of the site including previous flood events and historical high-water elevations,
- Developing the design flood events and low water flow,

---

<sup>7</sup> The *Alaska Highway Drainage Manual* is available online at the DOT&PF web site. It is based in part on the predecessor to the BDS.

<sup>8</sup> BDS Section 2.6 "Hydrology and Hydraulics" contains a complete outline of appropriate hydrology and hydraulic design criteria. Other sections refer to scour and foundation design.

- A hydraulic analysis including the effects of the new bridge in regard to high-water elevation, energy grade elevation, energy slope, and channel velocity,
- A scour analysis including the effects of channel contraction and pier and abutment scour depths,
- Abutment and bank protection including the size of riprap material, embankment slope and placement of armoring,
- Features as may be required for fish passage, ice movement and debris accumulation Coordinate fish passage analysis with State of ADF&G, Habitat Division,
- Coordination with the geotechnical engineer

A report outlining the above listed items and sealed by an engineer registered in the State of Alaska shall be provided.

## **4.2 Hydraulic Site Survey and Site information**

For each new bridge a hydraulic site survey shall be performed. This shall include:

- Provide a basis of survey including coordinate system, north arrow, survey monuments and project datum elevation.
- Identifying OHW elevation. Include a description of high-water evidence such as a distinct mark on the bank, erosion, shelving, changes in vegetation or other distinctive characteristics.
- A minimum of four cross-sections downstream and three upstream of the structure. Cross-sections are taken normal to the flow direction that defines the floodplain. The cross sections shall include the banks and channel bottom structure. They shall be spaced approximately one channel width apart. Each cross section shall be long enough to encompass the limits of the 500-year floodplain.
- A survey of horizontal and vertical location of other private and public structures that may be affected by the project and/or the hydraulic structure's performance. This may include downstream crossing if the new crossing will increase the channel cross section and remove a restriction to channel flow.

## **4.3 Hydraulic History of the Site**

For each new bridge identify and outline the hydraulic history of the site. This shall include records of past floods, available United States Geological Survey (USGS) records, local observations, high water marks and other historical data.

## **4.4 Design Flood Event**

Develop the flood magnitude estimations for the site, including the 50-, 100-, and 500-year flood events. This shall include the estimated flow rates and elevation for each event. Hydraulic Analysis

Model the 50-, 100-, and 500-year floods, and note design high water elevation, energy grade elevation, energy slope, channel velocity and Froude number. In most cases a one-dimensional

Hydrologic Engineering Centers River Analysis System (HEC–RAS) computer model will suffice for this. Both the existing condition and the condition with the proposed bridge shall be modeled.

Conduct a floodplain study and compare the results to FIRM maps, to determine what the backwater elevation increases will be as a result of the bridge. Provide design methods to alleviate unwanted increases.

#### **4.5 Scour Analysis**

Analyze scour potential for the proposed structure for the 100-year and 500-year floods, including estimated degradation, contraction, abutment, and pier scour depths.

Provide counter measures for scour.

#### **4.6 Ice Analysis**

Report shall recommend ice thickness and strength for structural design of piers. Provide recommendations for use with BDS ice load provisions.

#### **4.7 Clearance**

The minimum vertical clearance between the lowest member on the structure (low chord) and the 100-year flood shall be 3 feet, except where larger clearance is required by the USCG for navigable waterways. The designer shall also consider whether larger clearances are required for debris, ice, and aufeis, based on the environment and the potential for ice or log jams.

The hydraulics and hydrology report shall specify the clearances required for bridge design.

#### **4.8 Abutment and Bank Protection**

Provide the size of rip rap required, the method of placement (to include geotextile or filter fabric underlayment), the extents of the protected areas, and the depth of the key and length of toe.

Vegetative streambank stabilization measures should be employed where flow levels are appropriate.

#### **4.9 Fish Passage Analysis**

Determine whether the stream contains anadromous fish or not. ADF&G, Division of Habitat, maintains a catalog of waters deemed important to the spawning, rearing or migration of anadromous fish. If the stream in question is listed by ADF&G as anadromous, provide a bridge or a fish passage culvert in accordance with Section 7 of this chapter, and coordinate with the ADF&G, Habitat Division for construction permitting.

#### 4.10 Storm Water Drainage

The bridge structure and approaches must conform to the current Alaska Storm Water Regulations, both for the construction and in service maintenance periods.

## 5 Structural<sup>9</sup>

### 5.1 General

Design new bridges, including buried structures such as culverts, in accordance with the BDS, as modified herein.

Bridge design and construction shall be based on the materials and other requirements described in the “SSHHC” as modified herein.

### 5.2 Deck

Bridge decks shall be cast-in-place or pre-cast reinforced concrete at least 6 inches thick. All reinforcing steel in the deck shall be epoxy-coated (for precast girders this includes the stirrups). The concrete cover on reinforcing steel in cast-in-place and pre-cast decks shall be at least 2.5 inches. Use a full-width membrane on all concrete bridge decks, overlaid with four inches of asphalt<sup>10</sup>. Include 50 psf for the total dead load of surfacing on concrete decks.

Open-grid steel decks shall not be used.

Stay-in-place forms may be used only with the prior approval of the MSB.<sup>11</sup>

If the ADT is less than 400<sup>12</sup>, then a preservative-treated timber deck conforming to the BDS and Section 5.5 may be used. Unless otherwise permitted by the MSB, timber decks shall be provided with a bituminous wearing surface at least two inches thick in accordance with the BDS (either plant mix asphalt or chip seal). An allowance of 26 psf for the dead load of future surfacing on timber decks is required.

---

<sup>9</sup> Most of these requirements are from the DOT&PF *Pre-construction Manual* (as of 2013) and comments by DOT&PF on this document. The *Manual* requirements have been modified to improve clarity and to change references to the chief bridge engineer, the state foundation engineer, and the state geotechnical engineer.

<sup>10</sup> This allows future milling operations without damaging the membrane.

<sup>11</sup> Stay-in-place forms are discouraged because they hinder future inspection of the under-side of the deck. Stay-in-place forms have been accepted on a case-by-case basis in Alaska – most often in steel box girders, where they also improve lateral and torsional stiffness during construction.

<sup>12</sup> A road with an ADT less than 400 is considered to be a very low volume road. For example, in a suburban setting, a local road with an ADT of 400 might serve 40 residences.

### **5.3 Superstructure**

The bridge superstructure (girders, beams, diaphragms) shall be reinforced concrete, pre-stressed concrete, or steel. See Section 5.10 for use of rail cars and other non-bridge components for bridge superstructure.

Exception: if the ADT is less than 400, and if not prohibited by environmental permit requirements, then the bridge superstructure may be preservative-treated timber. See Section 5.5 regarding the use of preservative-treated wood.

### **5.4 Substructure**

#### **5.4.1 Materials**

The bridge substructure (abutments, piers, foundations) shall be constructed from any combination of the following materials:

- cast-in-place or pre-cast reinforced concrete or pre-stressed concrete,
- steel piles,
- reinforced concrete piles or piers.

Also, Mechanically Stabilized Earth (MSE) systems may be used to support abutments of bridges, under the following conditions:

- MSE systems are prohibited at all water crossings,
- if used for multi-span bridges, differential settlement between piers and abutments shall be addressed in the geotechnical report and the structural computations,
- if piles are used with MSE systems, the geotechnical report and structural computations shall consider vertical and lateral interactions between the two components.

Exception: if the ADT is less than 400, and if not prohibited by environmental permit requirements, then preservative-treated wood abutments and piers may be used, including preservative-treated timber piles. See Section 5.5 regarding the use of preservative-treated wood.

#### **5.4.2 Elastomeric bearings**

Elastomeric compounds used in the construction of bridge bearing pads shall contain only virgin natural polyisoprene (natural rubber) as the raw polymer. Do not use Neoprene. The prohibited use of Neoprene is unique to the MSB. ASBM allows for the use of Neoprene depending on the availability of natural rubbers. Use design method "B" in accordance with BDS Article 14.7.5.

## 5.5 Use of preservative-treated wood

As noted in previous sections, preservative-treated wood may be used for bridge components if not prohibited by environmental permit requirements. In addition, notwithstanding the requirements of SSHC Section 714:

- All treated wood products in this project<sup>13</sup> shall be produced in compliance with the BMP.
- All treated wood in this project shall be certified by an independent third-party inspection agency to have been produced in compliance with the BMPs.
- Bridge construction contract documents shall require the contractors and pertinent sub-contractors to be familiar with and apply as appropriate the installation and maintenance guidelines in the BMPs.
- Do not use creosote-treated wood for components subject to frequent public contact (such as pedestrian/equestrian/bicycle railing).

## 5.6 Bridge rail

Of the multiple rail options provided in the Alaska Bridges and Structures Manual (ABSM), the MSB requires the use of DOT&PF “Alaska Multi-State Bridge Rail” unless an alternative is approved or directed by the MSB.<sup>14</sup> At culverts, alternatively use a traffic barrier that complies with the “*Pre-Construction Manual*.”

Bridges on residential and collector roads or bridges with pedestrian pathways shall have a rail with a minimum height of 42” and gaps between post no greater than 4” where the pedestrian traffic will be located.

## 5.7 Design live loads

### 5.7.1 Typical live load

The design live load shall be HL-93<sup>15</sup> for bridges on all of the following:

- major hauling routes
- routes to major shipping points
- routes to resource areas
- routes to an industrial site

The MSB will identify bridges on these routes.

---

<sup>13</sup> As of 2020, the SSHC s only require “timbers” to be produced in compliance with the BMPs; they do not require glued-laminated products and piling to be produced in compliance with the BMPs.

<sup>14</sup> Some other crash-tested rail (such as a concrete shape) may be desirable in some circumstances; such bridge rail shall comply with NCHRP 350 Test Level Three. These requirements are from the “*Pre-Construction Manual*” (as of 2013). NOTE: on very low volume, low speed local roads, Test Level One may be appropriate since, according to the BDS ¶13.7.2, p. 13-7, Test Level One is “taken to be generally acceptable for...very low volume, low speed local roads.”

<sup>15</sup> This is the current design load required by DOT&PF and the BDS for highway bridges. The HL-93 loading corresponds to a uniform lane load plus a tractor-trailer weighing 36 tons or a single tandem trailer with closely spaced axles weighing 25 tons.

Also, the design live load shall be HL-93 for:

- bridges with total span of 100 feet or more between abutment bearings
- bridges with two or more traffic lanes in each direction
- any bridge funded in whole or part by federal aid
- any other bridge specifically identified by the MSB to be designed for HL-93

### **5.7.2 Reduced live load for low truck-volume roads<sup>16</sup>**

If the Average daily truck traffic (ADTT) is between 100 and 1000, inclusive, then 95 percent of the force effect of HL-93 may be used for design, and if the ADTT is less than 100, then 90 percent of the force effect of HL-93 may be used.

No other reductions in design live load will be allowed, regardless of traffic volume.

The ADTT and percentage of HL-93 used for design shall be shown on the design drawings.

## **5.8 Seismic – special requirements**

The “*Guide Specifications for LRFD Seismic Bridge Design*” may be used in lieu of the seismic requirements in the BDS.

The ends of the superstructure of simply supported multiple span structures shall be tied together and to the substructure with longitudinal restrainers designed for the force specified in the BDS.

Do not use skew angles for bridges greater than 30 degrees unless approved by the MSB.

Do not use steel rocker bearings.

Provide all bearings with transverse restraints.

Anchor bolts shall not be used to resist lateral loads.

Provide all abutments with a full-width, continuous-bearing seat.

---

<sup>16</sup> These provisions are from BDS, 2008 Interims, 3.6.1.1.1 commentary, p. 3-18. They will result in slightly more economical bridges for routes with low truck volume while still allowing safe passage of fire trucks, concrete trucks, fuel and water trucks, busses, etc. For reference, Indiana Department of Transportation Design Memorandum No. 07-05, dated March 22, 2007, lists the following approximate weights of typical vehicles: school bus carrying up to 84 passengers (15 tons), loaded garbage truck (27 tons), single-unit fire engine (27 tons), loaded ready-mix-concrete truck (30 tons), and tractor-apparatus fire engine (36 tons). These example vehicle weights have not been verified and should not be used for design.

For concrete abutment and retaining walls, use dowels in addition to normal shrinkage and temperature steel on the compression face to connect the stemwall to footing. Concrete spread footings for abutments and piers shall have reinforcement in the top face to resist seismic forces. Concrete footing reinforcement in abutments and piers shall be a minimum reinforcement of #8 bars at 8 inches each way, top and bottom.

Extend concrete column reinforcement as far as possible into the pier cap beam and footing.

Splices of vertical concrete column reinforcement shall occur only within the centermost (mid-height) section of columns or in accordance with the *“Guide Specifications for LRFD Seismic Bridge Design.”*

### **5.9 Skewed bridges**

In a skewed bridge, the loads tend to distribute to the supports in a direction normal to the support. This causes a greater portion of the load to be concentrated at the obtuse corners of the span and less at the acute corners. The structural computations shall demonstrate that this effect has been evaluated. On concrete girders, additional shear reinforcing shall be provided; on steel girders, additional transverse stiffeners may be required, depending on diaphragm type and location.

### **5.10 Use of railcars and other non-bridge structures**

Use of non-bridge components such as flat rail cars, truck trailers, and landing ramps (all of which are hereafter called “non-bridge components”) for the superstructure of bridges is discouraged, whether refurbished or not, and is allowed only under the following conditions:

- ADT is less than 100.
- A Professional Engineer, registered in the State of Alaska, shall evaluate the condition of the non-bridge components and shall rate the non-bridge component’s deck and structure capacity in accordance with the *“Manual for Bridge Evaluation”* using the Design Load Rating procedure for the HL-93 loading at the Inventory level.
- Calculated Rating Factor (RF) shall not be less than 0.90.
- In addition to all other required computation submittals, the load rating computations shall be sealed and submitted to the MSB for their records.
- Abutments, deck, bearings, connections, and all other bridge elements shall be designed in accordance with the BDS for at least the rated load.
- The ADT and percentage of HL-93 used for design of the abutments shall be shown on the design drawings.
- The deck wearing surface shall comply with the BDS and shall be preservative-treated timber planks securely fastened to the deck, or plant-mix asphalt or chip seal.
- Bridge rail shall comply with Section 5.6

### 5.11 Welding

All welding shall be in accordance with *SSHC* Section 504. The minimum level of non-destructive examination is specified in American Welding Society (AWS) D1.5 Section 6.7. The contractor shall provide all required QC inspection and non-destructive examination.

## 6 Stream Crossing Culverts

### 6.1 General Requirements

The following criteria apply to all culverts that cross waterbodies, such as rivers, lakes, streams and drainage ways with intermittent flow:

- Prior to preliminary plat submittal, contact the ADF&G, Division of Habitat to determine if a stream reach harbors fish. If so, stream crossing culverts shall be designed, constructed, and maintained according to section 6.2 Fish Passage Culverts.
- Stream crossing culverts shall be placed as close to the pre-existing channel alignment as possible. Avoid placing culverts at pools and stream bends.
- Road alignment shall be as close to perpendicular to the stream channel as possible.
- Culvert slope shall be within 25 percent of the natural stream slope. For example, if the natural stream slope is 1.0 percent, the minimum design slope of the culvert would be 0.75 percent and the maximum design slope would be 1.25 percent.
- Culvert outlet and inlet protection shall be used as necessary to reduce the risk of scour and perching.
- Stream crossing culverts shall be composed of a single pipe or arch for at least the bankful width of the stream channel. Additional width is required for streambanks in fish passage culverts per section 7.1.
- Overflow culverts may be used but should be placed at a higher elevation so that flows up to the ordinary high-water mark (OHWM) pass through the primary culvert.
- Stream crossings shall maintain the connectivity of wetlands adjacent to stream channels and shall accommodate sheet flow within such wetlands.
- Stream crossing culverts shall not interfere with the functioning of floodplains and shall be designed to accommodate the 100-year flow.
- In cases of crossings within high entrenchment ratio environments, the ratio of the flood prone width to the OHW width is greater than 2.2, floodplain overflow culverts may be beneficial to floodplain connectivity and can be used to pass the design flow. Minimum width requirements for the primary culvert still apply.
- Stream crossing culverts shall have a minimum diameter of three feet.
- Stream crossing culvert pipes and arches shall be metal.

- Round stream crossing culverts shall have a minimum invert burial depth in the stream substrate of forty percent (40%) of the culvert diameter, as measured from the thalweg.
- Box culverts and pipe arch culverts, should have a minimum invert burial depth of twenty percent (20%) of the culvert's rise into the substrate.
- Bottomless culverts with footers need to have sufficient burial depth and armor material to protect the footings from potential scour over the life of the structure.
- Culverts longer than 100 feet require appropriate maintenance access.

## **6.2 Fish Passage Culverts**

These criteria provide general design guidance for road, pathway or other crossings of fish-bearing streams using culverts to maintain the full hydrologic functioning of the water body they are crossing. Site-specific conditions, such as multi-thread or braided channels, may require alternate design approaches, such as a bridge.

### **6.2.1 Pre-design Conference**

For privately owned roads, schedule a fish passage pre-design conference with DPW prior to permit submittals. The pre-design conference is to:

- determine required permits,
- coordinate interagency requirements,
- determine any site-specific design requirements; and
- establish a plan review process.

### **6.2.2 Stream Simulation Method**

Stream simulation methodologies shall be used for the design of all fish-bearing stream crossings. The stream simulation method uses reference data from a representative section, or reference reach, of the specific water body crossed. This method attempts to replicate the natural stream channel conditions found upstream and downstream of the crossing. Sediment transport, flood and debris conveyance, and fish passage are designed to function as they do in the natural channel.

#### **Reference Reach Investigation**

- The design engineer shall select a reference reach on the water body being crossed that is outside any anthropogenic influence, such as an existing culvert. In most cases for new crossings, the reference reach can be at the crossing location.
- The length of the reference reach should be a minimum of 20 times the reference bankfull width and no less than 200 feet and shall include at least 3 stable grade control features.
- If there is not a suitable reference reach on the water body being crossed, a reference reach may be chosen from another water body with similar geomorphic and hydrologic

characteristics. The reference reach characteristics should meet the following criteria in comparison to the water body being crossed:

- The reference reach bankfull width should be at least one-half and no more than two times that of the water body being crossed.
- The reference reach bankfull discharge should be at least one half and no more than one- and one-half times the bankfull discharge of the water body being crossed; and
- The stream order of the reference reach should be within one stream order of the water body being crossed.
- For a reference reach from another water body, the geomorphic characteristics of the crossing shall be scaled using ratios of the bankfull conditions.
- The reference reach bankfull dimensions should be determined in the field by surveying a detailed cross section at the upper 1/3 of a representative riffle.
- Reference data shall include, at a minimum:
  - channel width at OHW,
  - bankfull width,
  - bankfull cross-sectional area,
  - bankfull slope based on the longitudinal profile,
  - substrate, and
  - potential for floating debris.

### **Culvert Size, Slope, and Substrate**

In addition to the criteria identified in Section 6.1, the following criteria apply to all fish passage culverts:

- **Minimum Sizes:** Round culvert pipes shall have a minimum diameter of seven (7) feet and full-invert box arch culverts should have a minimum height of seven (7) feet. Culverts shall have a minimum vertical clear distance of four (4) feet from the constructed stream thalweg to the top of the culvert.
- Under normal flow conditions, the channel within or under the fish passage culvert shall not differ from the reference reach condition in regard to the channel width at OHW, cross-sectional area, slope, substrate, and ability to pass floating debris.
- The width of fish passage culverts shall not be less than the greater of 1.2 times the channel width at OHW and 1.0 times the bankfull width.
- The use of smooth wall culverts is prohibited.
- The use of trash racks or debris interceptors is prohibited.
- Round culvert pipes shall have a minimum invert burial depth of 40 percent of the culvert diameter into the substrate. Arch or box culverts shall have a minimum invert burial depth

of 20 percent of the culvert's rise into the substrate, unless scour analysis shows less fill is acceptable. The minimum invert burial depth is one foot.

- **Substrate Material:** The gradation of the substrate material within a fish passage culvert shall be designed to be a dense, well-graded mixture with adequate fines to ensure that the majority of the stream flows on the surface and the minimum water depth is maintained. The combined gradation should have a minimum of 5% passing the #10 sieve (2mm).
- Substrate material within or under the fish passage culvert shall remain dynamically stable at all flood discharges up to and including a 50-year flood. Dynamic stability means that substrate material mobilized at higher flows will be replaced by bed material from the natural channel upstream of the crossing. For crossings without an adequate upstream sediment supply, the substrate material within the crossing shall be designed to resist the predicted critical shear forces up to the 100-year flood. For culverts in sand bed channels or with a slope of 6 percent or greater, substrate retention sills may be required to allow the bed load to continuously recruit within the culvert.
- If substrate retention sills are used, they shall have a maximum weir height of one half of the culvert invert burial depth. Substrate retention sills shall be spaced so that the maximum drop between weirs is 4 inches. The use of sills without substrate is not allowed.
- **Low Flow Channel:** Substrate material within or under the fish passage culvert shall incorporate a low flow channel. The low flow channel should mimic the reference reach where possible. If the low flow channel dimensions are not discernable from the reference reach, the low flow channel should have a cross-sectional area of 15 to 30 percent of the bankfull cross-sectional area and a minimum depth of 4 inches for juvenile fish and 12 inches for adult fish. The low flow channel should be defined by rock features that will resist critical shear forces up to the 100-year flood.
- **Streambanks:** Except as listed below, constructed streambanks shall be included inside fish passage culverts to protect the culvert from abrasion, provide resting areas for fish, capacity for flood stage flow increases and provide for small mammal crossing. The streambanks shall be constructed of rock substrate designed to be stable at the 100-year flood. The streambank width should be a minimum of 1.5 times the maximum sieve size of the streambed material ( $D_{100}$ ). The crossing culvert width shall be increased to allow for the channel width plus the streambanks.
- Streambanks are not recommended for the following locations:
  - Sand bed streams
  - Low slope (<1%) wetland complexes
  - Permafrost and aufeis areas
  - Streams with significant ice floes

## **7 Appendices**

### **7.1 Appendix 1 - Bridge Final Design Check List**

**Bridge Final Design Checklist**

№	DESCRIPTION	PREPARED	DATE
1.	Check Stationing against the roadway plans for each bridge structure: Bridge №: ____, Station _____. Bridge №: ____, Station _____. Bridge №: ____, Station _____.	_____ _____ _____	_____ _____ _____
2.	Check profile grade against the roadway plans for each bridge structure: Bridge №: ____, elevations at begin ____, end _____. Bridge №: ____, elevations at begin ____, end _____. Bridge №: ____, elevations at begin ____, end _____.	_____ _____ _____	_____ _____ _____
3.	Does the Hydraulic and Hydrologic Summary Table match the Final Hydraulic and Hydrologic Report?		
4.	Does Foundation Summary Table match the Final Foundation Engineering Report?		
5.	Does the bridge naming conform to standards		
6.	Have all of the bridge components been addressed in the Specifications for material requirements, construction tolerances, method of payment, etc?		
7.	Do the bridge plans sheets have the following titles? <ul style="list-style-type: none"> <li>• General Layout</li> <li>• Site Plan</li> <li>• MSE / Retaining Wall / Foundation Layout</li> <li>• Abutments</li> <li>• Abutment Details</li> <li>• Piers</li> <li>• Pier Details</li> <li>• Typical Section</li> <li>• Framing Plan</li> <li>• Girders</li> <li>• Girder Details</li> <li>• Miscellaneous Details</li> <li>• Approach Slabs</li> <li>• Steel Bridge Railing</li> <li>• Log of Test Holes</li> </ul>		
8.	Is the bridge number provided on all bridge plan sheets?		
9.	Does the vertical clearance under the bridge satisfy the DCM requirements?		
10.	Are all of the plans stamped and signed by the Engineer of Record?		
11.	Are all plans readable when reduced in size?		

12.	Have all of the applicable standard plans been identified?		
13.	Has all specifications language been included in the specifications and NOT on the plan sheets?		
14.	Has staged construction and traffic control been shown if required?		
15.	Have all cross references between plan sheets been verified?		
16.	Have bridge railing to roadway guardrail transitions been addressed?		
17.	Have provisions been made for current and future utilities (always inboard of the fascia girder) and blockouts in the diaphragms and backwalls?		
18.	Have bridge mounted utilities been shown and properly identified on the plans?		
19.	Are reinforcing steel schedules / bend diagrams provided on the bridge plans?		
20.	Check for embankment treatment (matching of dirt to wall) at abutments and wingwalls.		
21.	Check for side slope consistency or transition from roadway slopes (____) to bridge side slopes at abutment (____).		
22.	Have the Plans, Specifications, and Estimate been compared against one another and checked?		
23.	Do all of the pay item names and numbers match the specifications?		
24.	Is the terminology used throughout the PS&E used appropriately and consistently?		
25.	Is the PS&E free of brand names, product names, trade names, and other proprietary items?		
26.	Are all estimated quantities appropriately rounded?		
27.	Have nonstandard practice and items of work been reviewed and approved by the MSB?		